



RACING BUGGY 《HUNTER》

- STRAIGHT RIBBED FRONT RACING RUBBER TIRES.
- MONO-SHOCK TYPE SUSPENSION FOR REAR.
- CHANGEABLE PINION GEAR RATIOS (HIGH TORQUE) (STANDARD) (HIGH SPEED).
- DIFFERENTIAL GEAR DRIVE SYSTEM.
- DURABLE POLYCARBONATE BODY.
- READY TO ASSEMBLE MODEL KIT.
- ADJUSTABLE OIL DUMPED SHOCK

1/10 SCALE RADIO CONTROL OFF-ROAD RACING BUGGY SERIES HUNTER

PRODUCT BY TOKYO MARUI PLASTIC MODEL CO., LTD.

RACING BUGGY

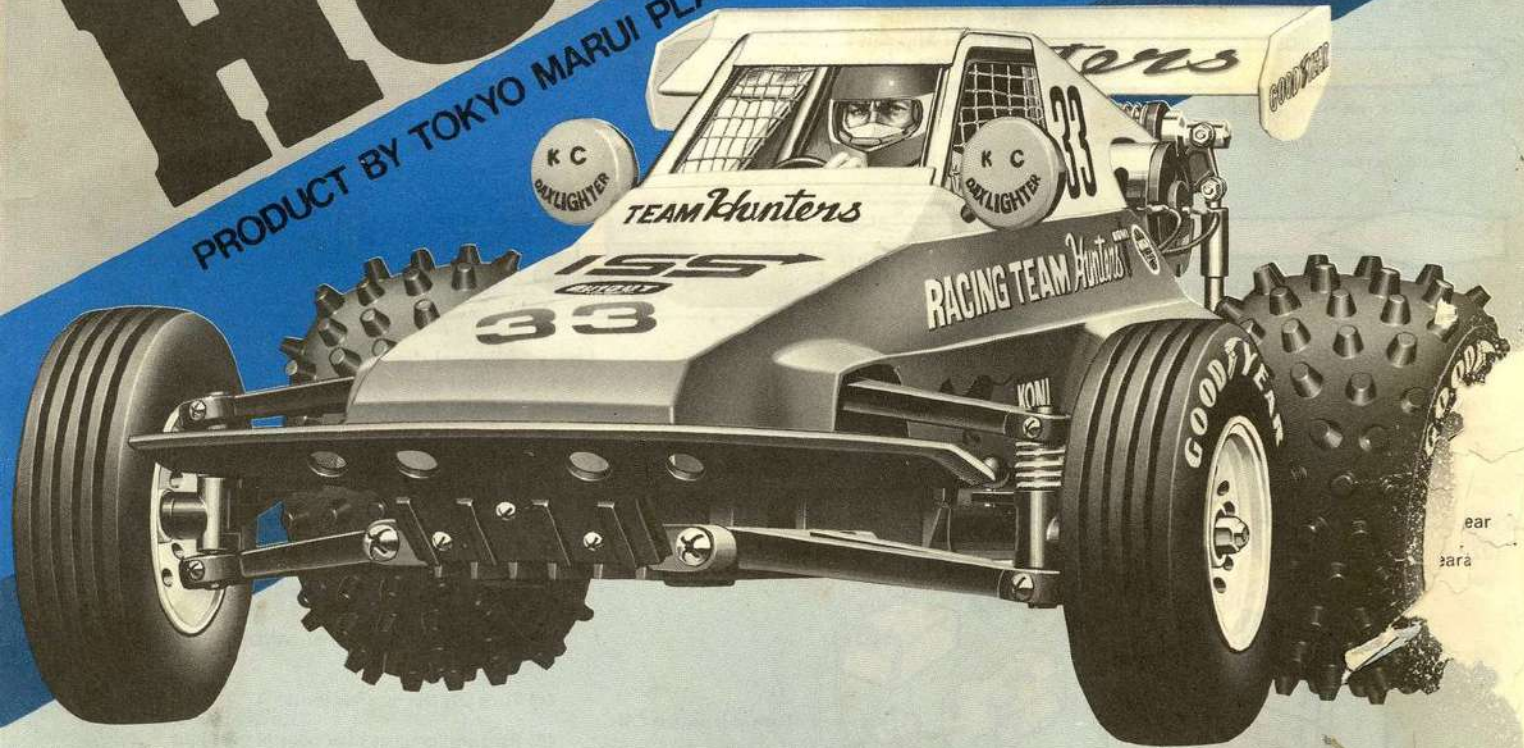

TOKYO MARUI PLASTIC MODEL CO., LTD.

HIGH QUALITY MECHANISM FOR OFF-ROAD RACING



RCScrapyard.net

Parts not included in the kit

- 2-channel proportional controller

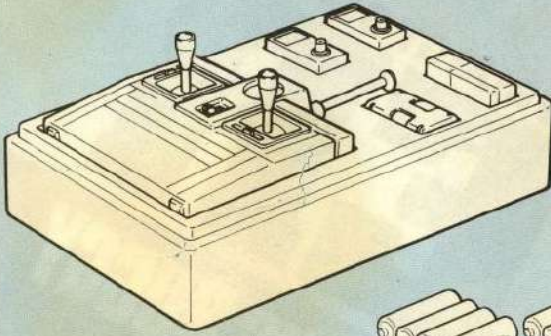

Majority of general type 2-channel unit is acceptable. Please be careful as some types are not suitable for this model.

The following are recommended:
 "ATTACK" of Futaba,
 "DASH" of Sanwa,
 "BEAT-2" of JR,
 or "FX-11" of KO



- Batteries for the proportional controller

Special battery charger

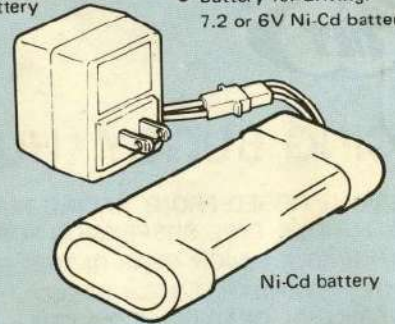

- Battery for driving:
7.2 or 6V Ni-Cd battery

Ni-Cd battery

Use 6 V Ni-Cd battery or 7.2 V racing Ni-Cd battery. These batteries may be recharged up to 300 times using a special charger connecting with household 100 V current or a quick charger connecting with a 12 V power supply such as a car cigarette lighter.

Required tools Actual sizes

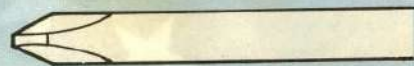

Phillips type screwdriver (Large)

Use for $\phi 3$, $\phi 3$ tapping, $\phi 4$ tapping screws.



Phillips type screwdriver (Middle)

Use for damper shaft, $\phi 2.6$ tapping screw, and $\phi 2$ screw.

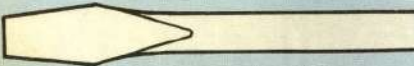

Plain screwdriver (Middle and Small)

This kit includes many tapping screws. Use the proper screwdriver for tapping screws. Use adequate torque to tighten screws. Release turning pressure on the screwdriver when the screw becomes tight and does not rotate any more. Be careful not to damage screws by applying too much torque.



Cutter knife

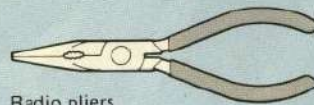

Radio pliers

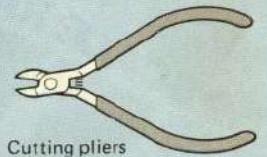

Cutting pliers

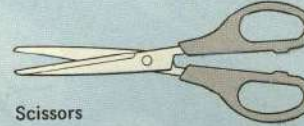

Scissors

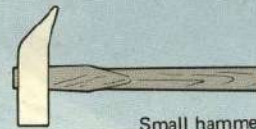

Small hammer

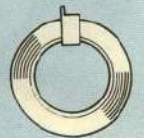

Insulation vinyl tape and scotch tape

Radio control unit

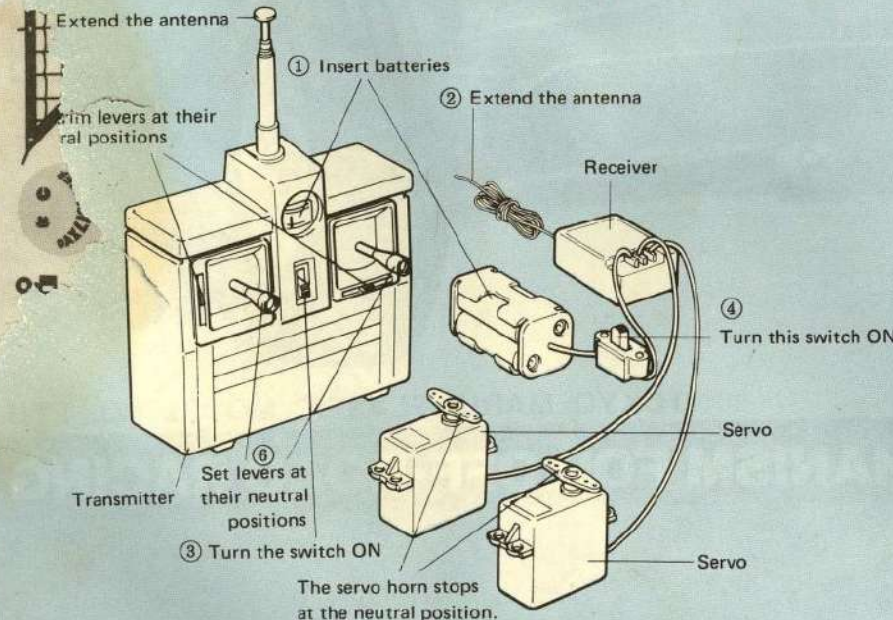

Use a 2-channel digital proportional radio controller for this model car. Be careful because certain types of controllers, such as the 3 8-channel proportional Controller's receiver and servo are not suitable.

Check the 2-channel proportional controller for correct operations as follows:

- (1) Insert batteries in the transmitter and receiver.
- (2) Extend antenna of transmitter and receiver.
- (3) Turn ON the transmitter switch. (Always turn ON the transmitter switch.)
- (4) Turn ON the receiver switch.
- (5) Set trim levers at their neutral positions.
- (6) Set levers at their neutral positions. (The servo horn stops at the neutral position.)
- (7) Check servoes for correct operations by moving levers.
- (8) Turn OFF the receiver and then transmitter switches in this order after test completion.

See the radio control equipment instruction sheet for details.

★ Read the following instructions carefully before assembly

- It is recommended to review the assembly instruction sheet before beginning assembly.
- Mark indicates the portions where grease included in the kit must be applied. Use a small hammer wherever the mark is shown in the figure.
- The actual sizes of all screws, washers, etc. are shown to simplify the assembly and ensure that correct parts are used.

- Some screws, nuts, and washers may be left over as more than required numbers are included in this kit. Use them as spare parts.
- Thoroughly remove plastic part burrs using a cutter knife.

* Strengthened nylon part burrs must be completely removed as they may impair driving performance. (Be careful not to cut your fingers with a cutter knife.)

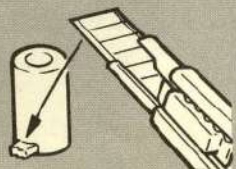

Metallic part actual sizes used on P. 3

- $\phi 3 \times 10$ tapping screw ... 2 pcs
- $\phi 3 \times 12$ tapping screw ... 4 pcs
- $\phi 3 \times 8$ screw ... 2 pcs

- 2 mm nut ... 2 pcs
- 3 mm nut ... 8 pcs
- 3 mm washer ... 8 pcs
- 3 mm spring washer ... 6 pcs

- $\phi 3 \times 4.5$ spacer ... 4 pcs
- Oilless metal ... 2 pcs
- Front suspension shaft (Short) ... 2 pcs

- Front shaft ... 2 pcs
- Free ball (A) ... 2 pcs

- Front suspension shaft (Middle) ... 2 pcs
- Front damper spring ... 2 pcs

1 Components assembly

Mounting the under guard

● In case of using a 7.2 V battery:

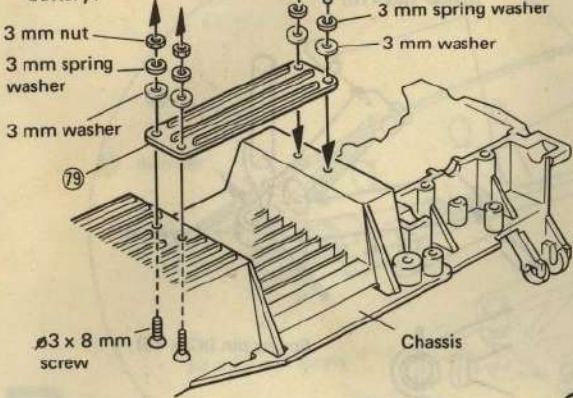

● In case of using 6V battery:

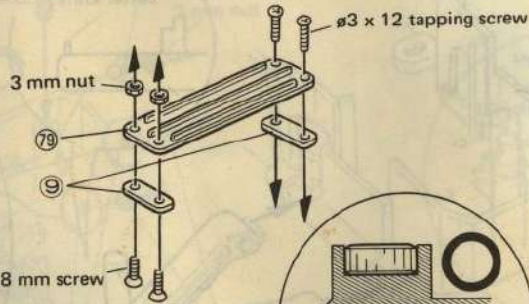

Driving in the metal



Bonding driver's parts

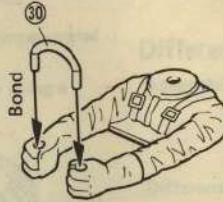
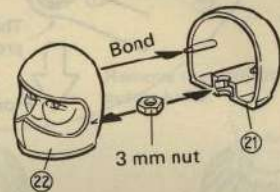

2 Front damper and knuckle arm assembly

Front damper

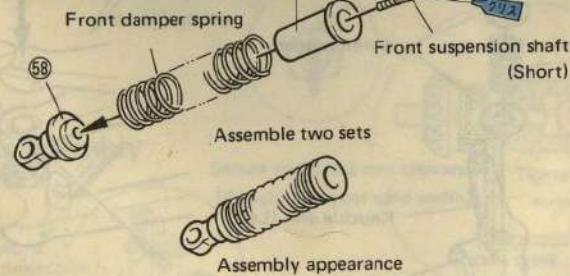

Right

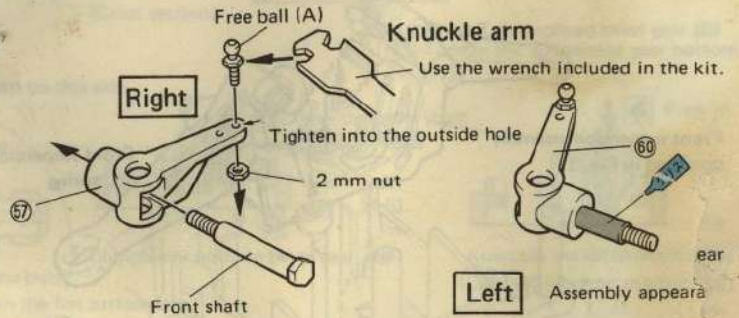

Left

Assembly appears

3 Front suspension assembly

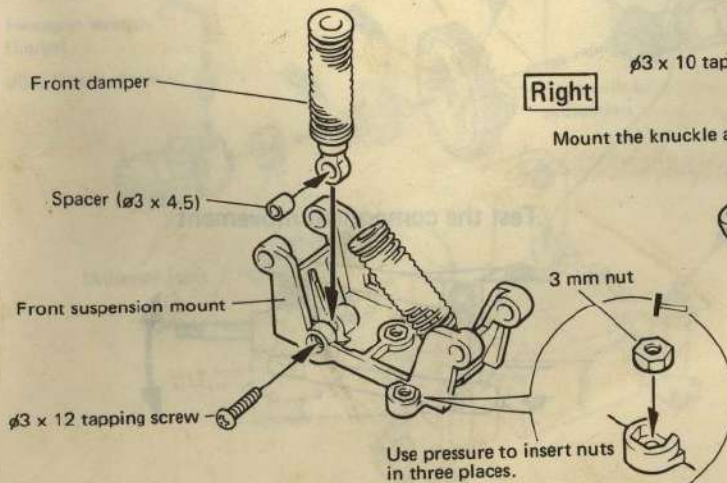

Right

Mount the knuckle arm R on this side

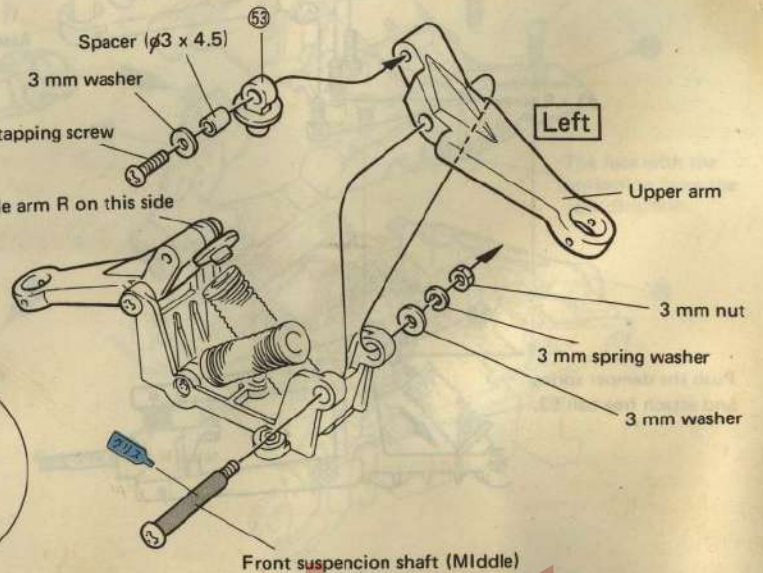

Left

Metallic part actual sizes used on P. 4

 $\phi 3 \times 8$ screw ... 3 pcs



6 mm washer ... 4 pcs



Front suspension spring ... 2 pcs

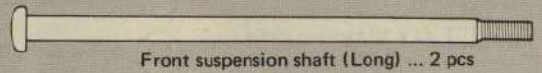

Front suspension shaft (Long) ... 2 pcs

 Spacer $\phi 3 \times 10$... 4 pcs

 Spring pin ... 4 pcs $\phi 2 \times 16$

4 Lower arm assembly

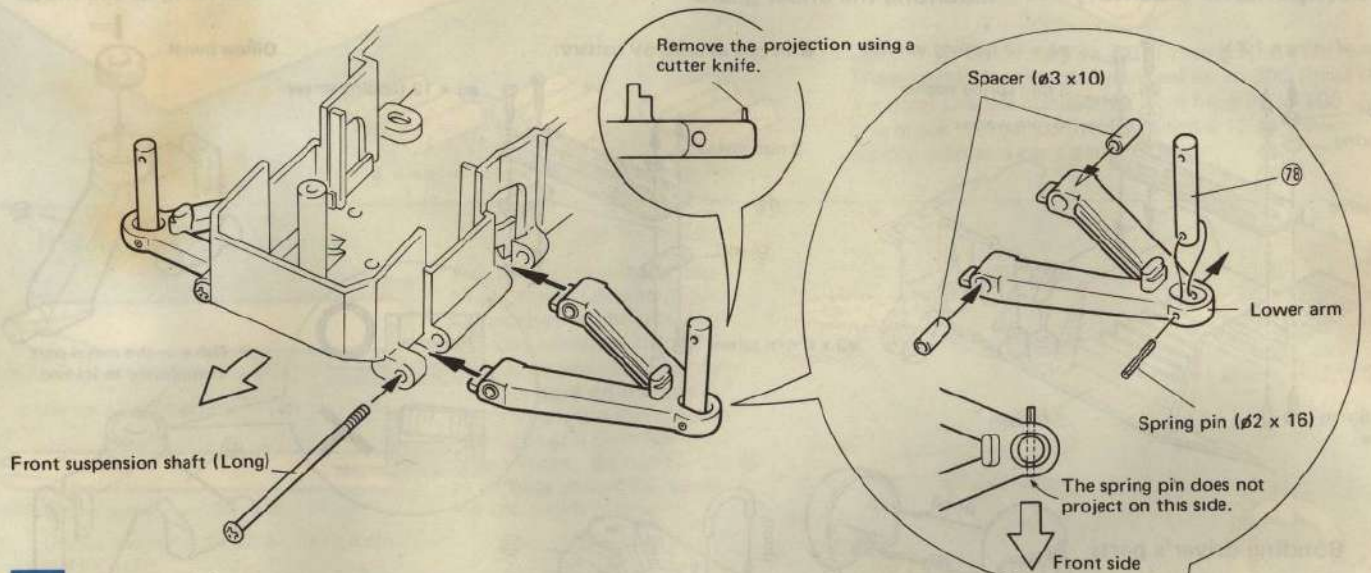

5 Mounting front suspension

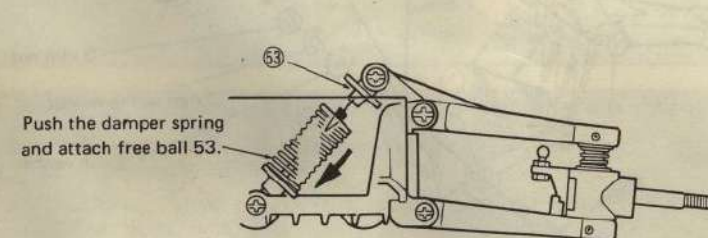
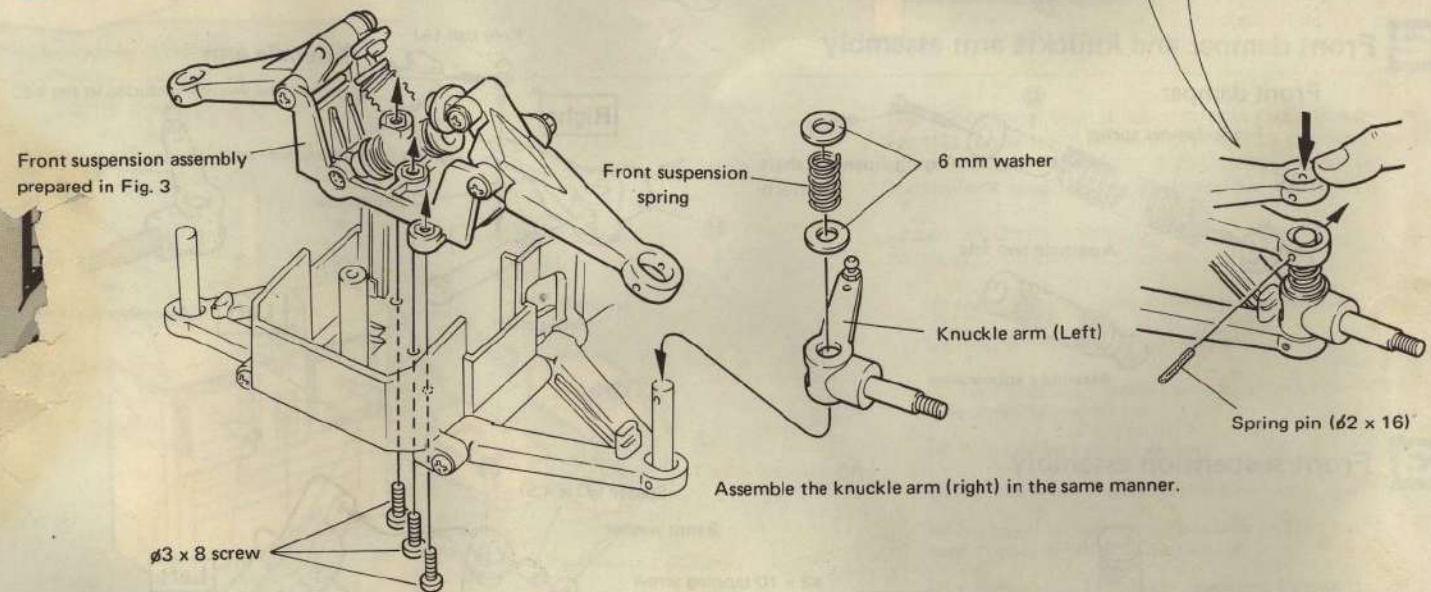

Test the component movement

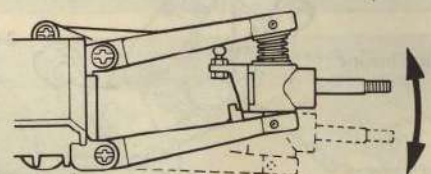

Metallic part actual sizes used on P. 5

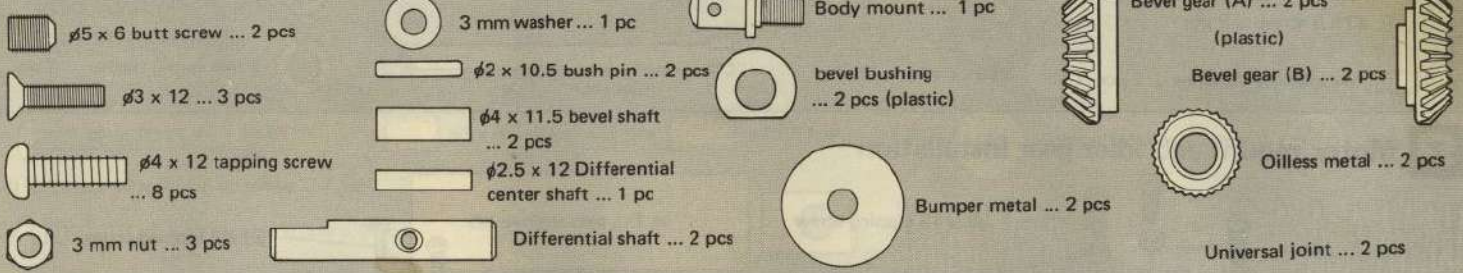

6 Bumper and body mount installation

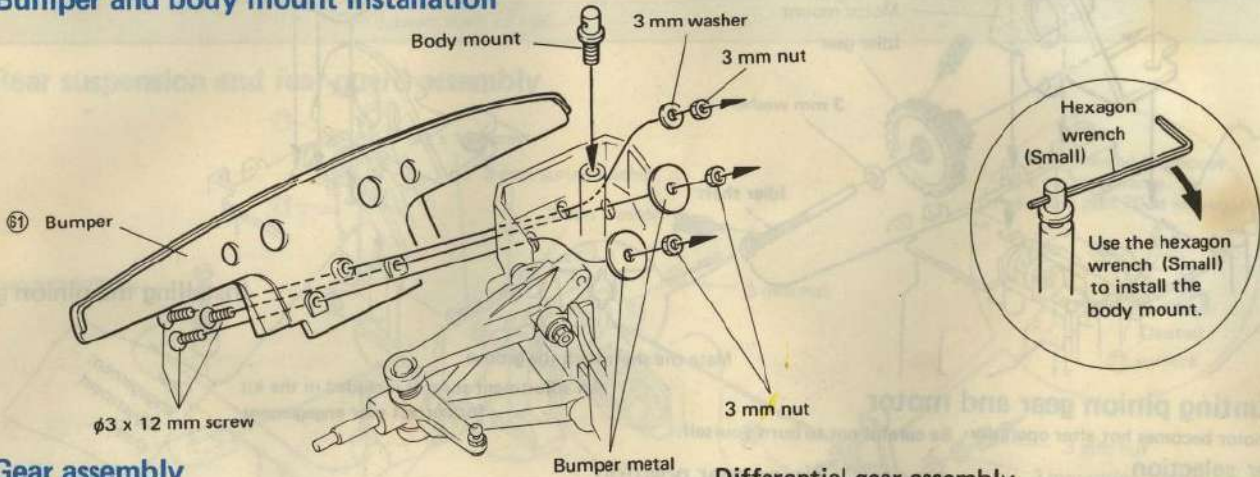

7 Gear assembly

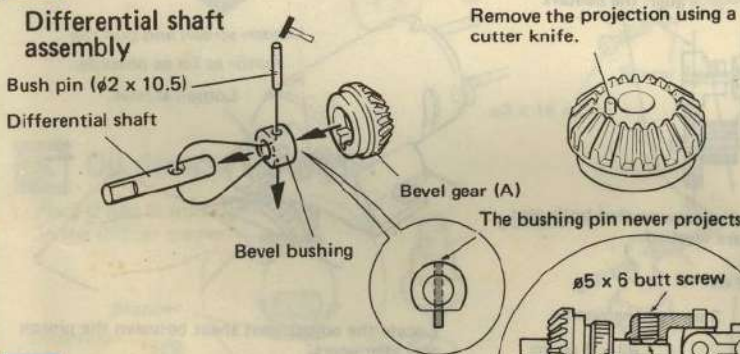

Differential gear assembly

Assemble instructions 1 through 4 in order.

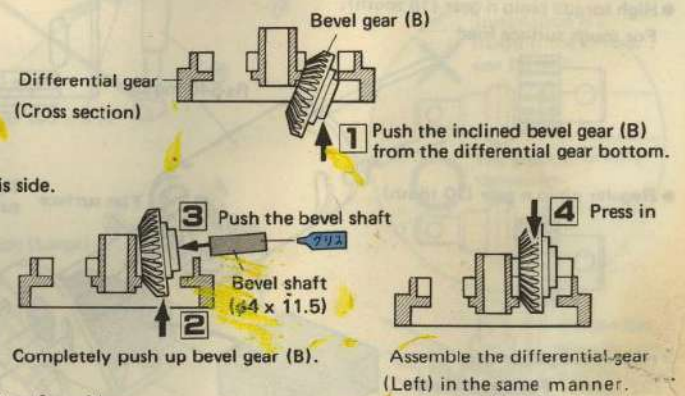

8 Gear assembly

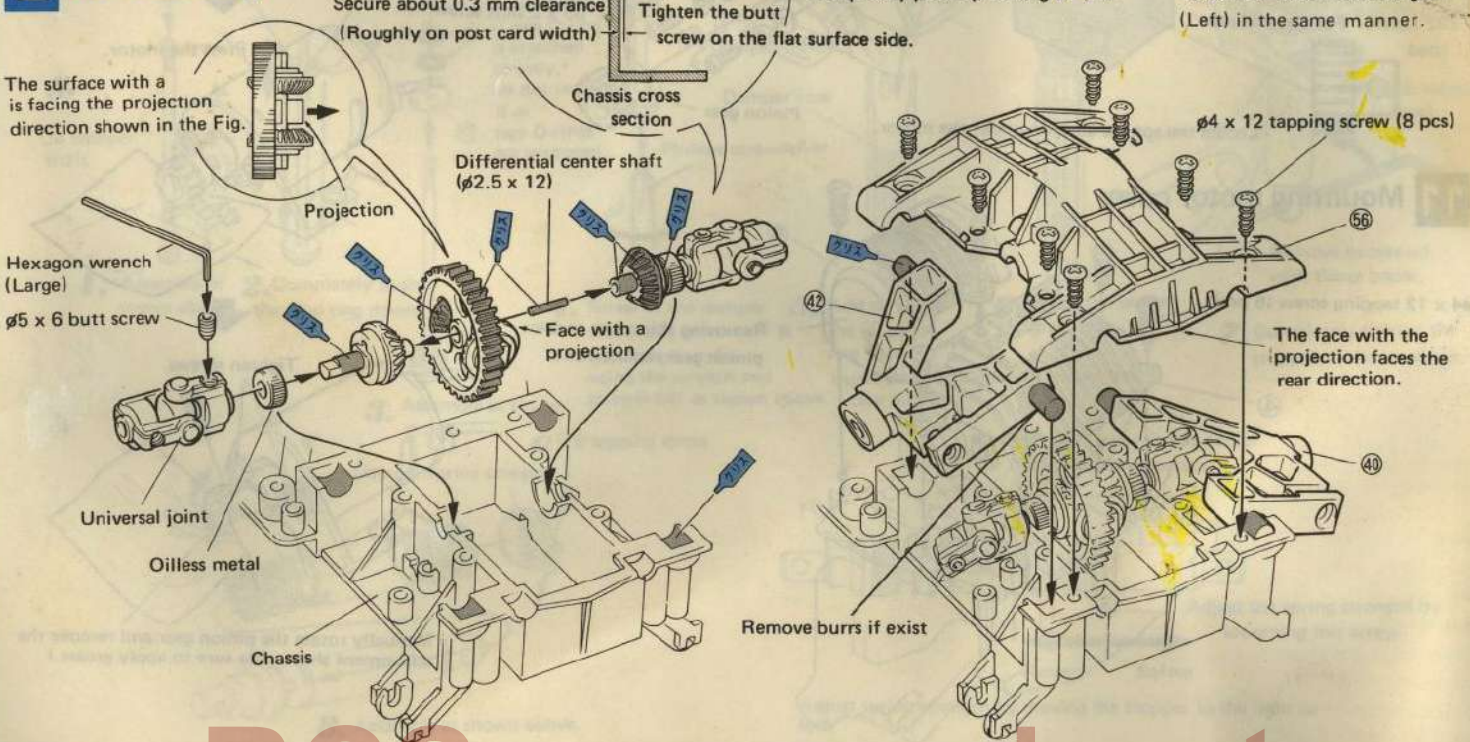

Metallic part actual sizes used on P. 6

ϕ3 x 6 screw ... 2 pcs

ϕ3 x 8 tapping screw ... 2 pcs

ϕ4 x 12 tapping screw ... 9 pcs

ϕ3 x 3 butt screw ... 1 pcs

3 mm washer ... 3 pcs

Idler shaft ... 1 pc

3 mm spring washer ... 2 pcs

4 mm spring washer ... 3 pcs

9 Motor mount and idler gear installation

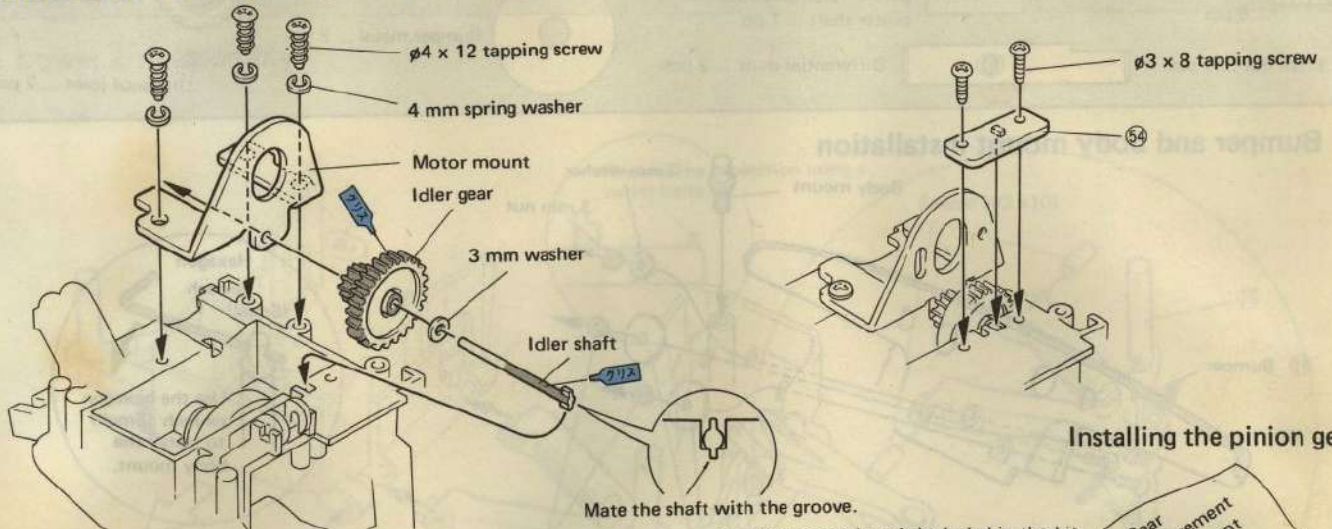

10 Mounting pinion gear and motor

The motor becomes hot after operation. Be careful not to burn yourself.

Pinion gear selection

Determine the proper pinion gear for driving conditions.

- High torque pinion gear (18 tooth): For rough surface load



- Regular pinion gear (20 tooth)



- High speed pinion gear (22 tooth): For flat surface road



Pinion gear position

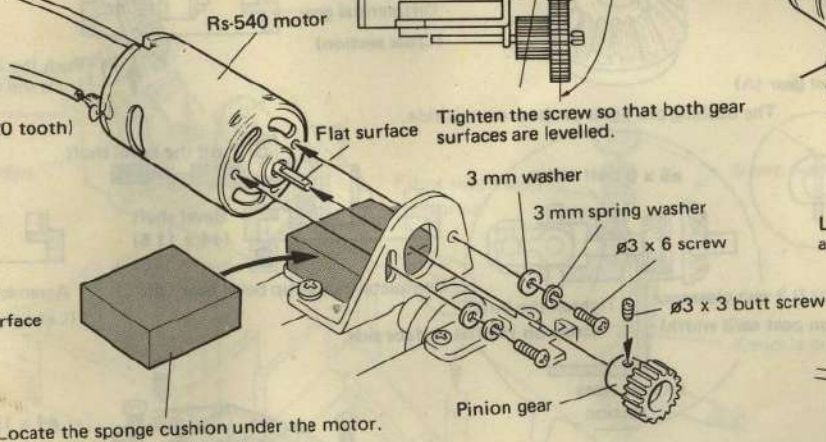
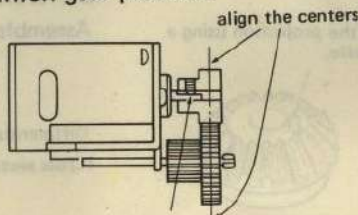

Locate the sponge cushion under the motor.

An adjustment sheet is included in the kit for correct gear engagement

Installing the pinion gear



Loosen screws and pull the motor as far as possible. Loosen screws.

Locate the adjustment sheet between the pinion and idler gears.

Press the motor.

Tighten screws.

Manually rotate the pinion gear and remove the adjustment sheet. (Be sure to apply grease.)

11 Mounting motor cover

ϕ4 x 12 tapping screw (6 pcs)

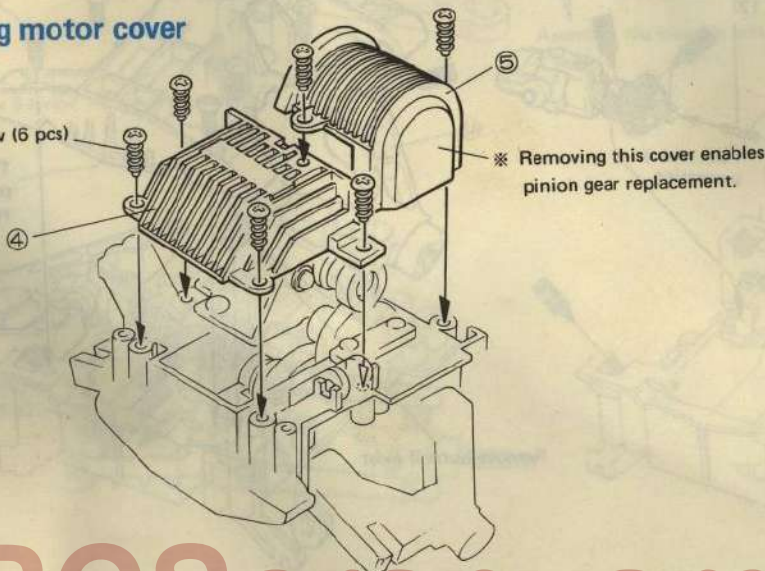

Metallic part actual sizes used on P. 7

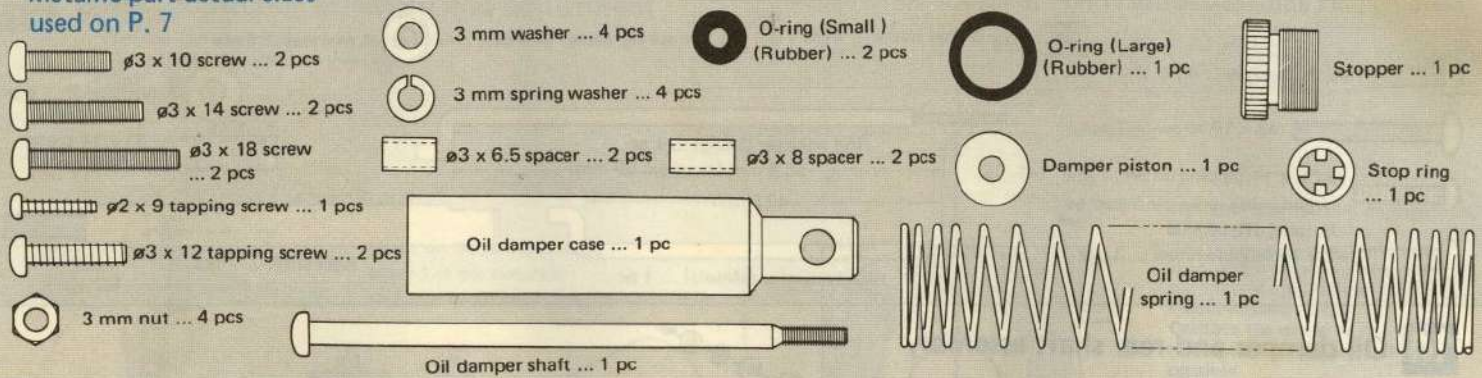

12 Rear suspension and rear guard assembly

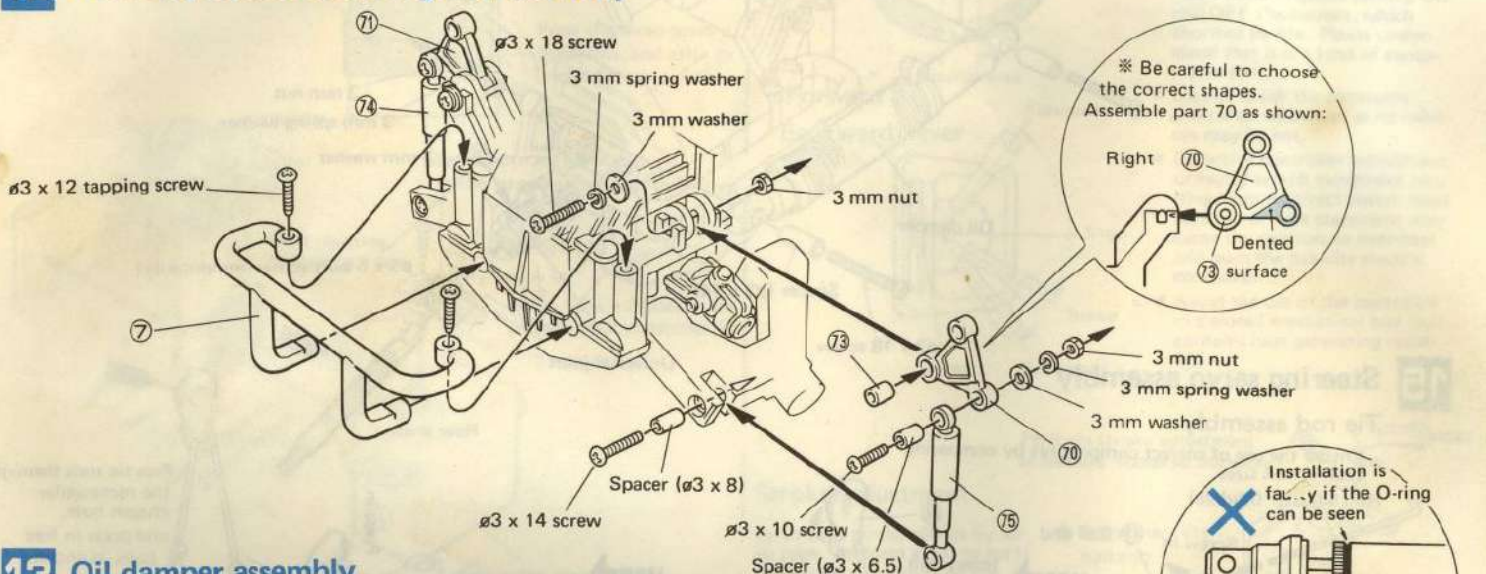

13 Oil damper assembly

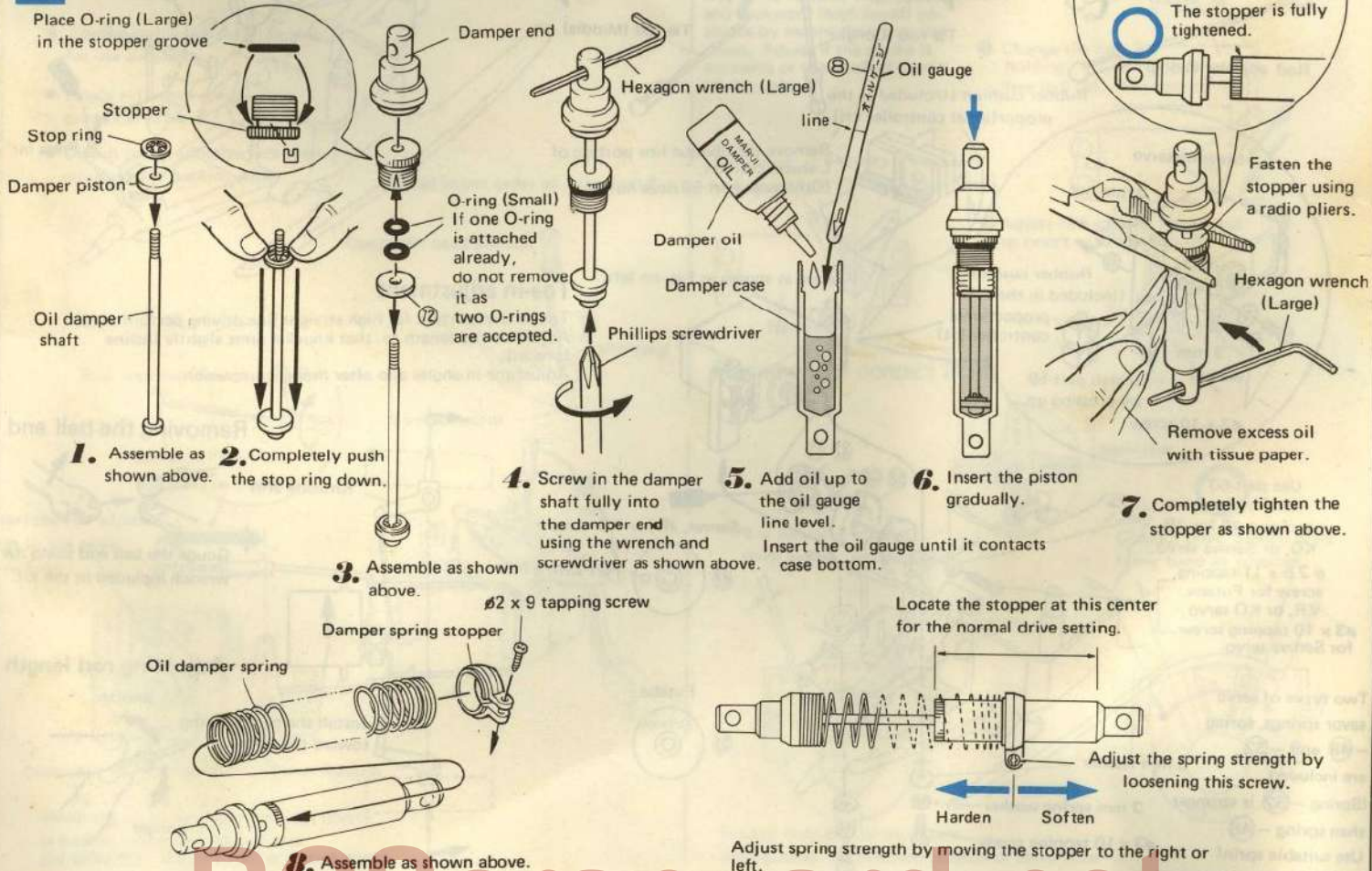

Metallic part actual sizes used on P. 8

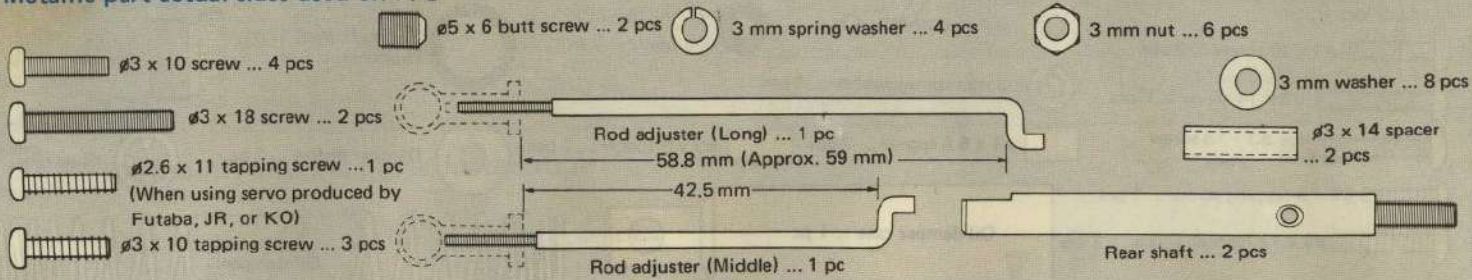

14 Oil damper and rear shaft assembly

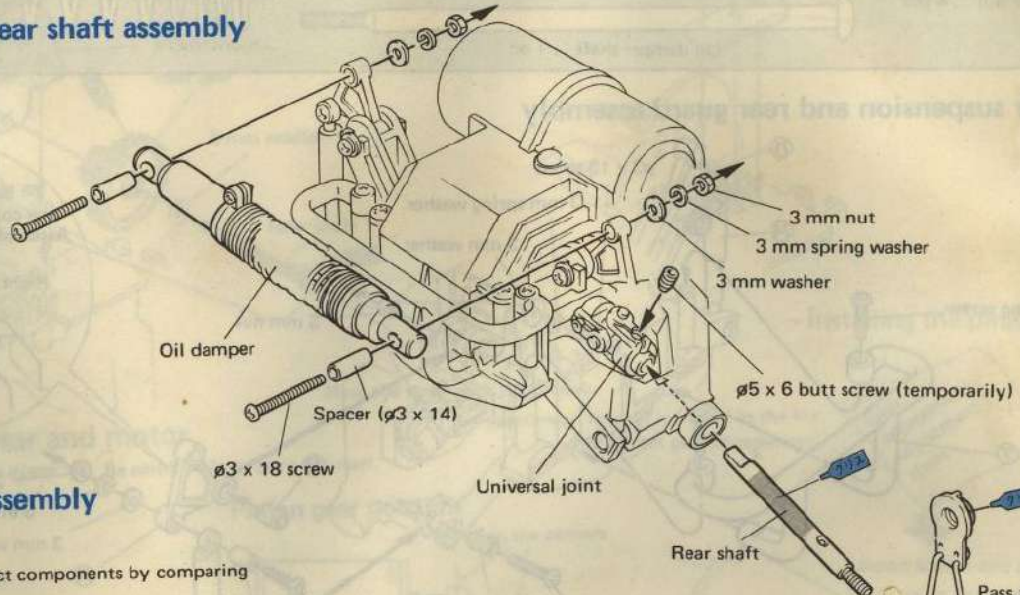

15 Steering servo assembly

Tie rod assembly

※ Ensure the use of correct components by comparing their actual sizes.

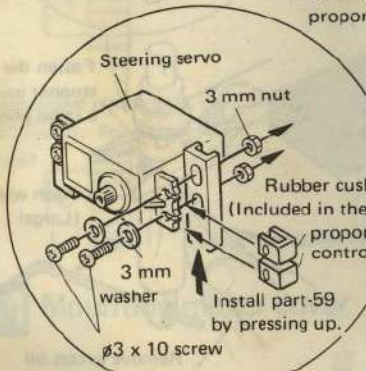
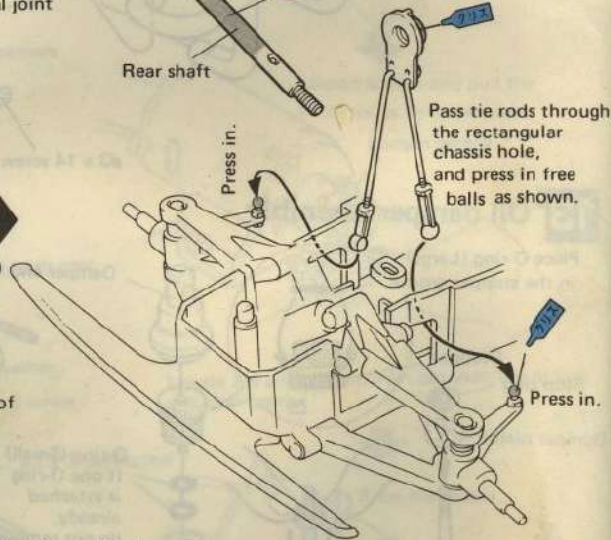
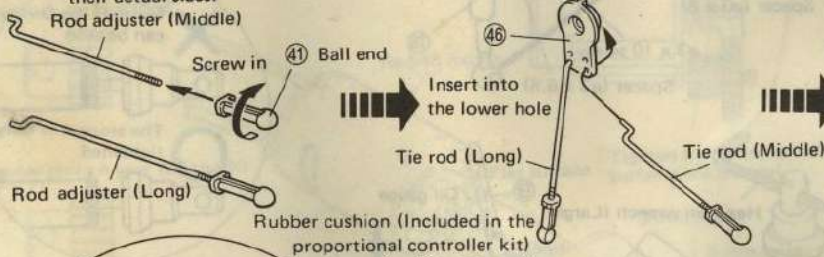

Toe-in adjustment

Toe-in is important for high straight line driving performance. Adjust tie rod length so that knuckle arms slightly incline forward. Adjust toe-in angles also after model completion.

Use part-50 for Futaba servo, and part-49 for JR, KO, or Sanwa servo.
 $\varnothing 2.6 \times 11$ tapping screw for Futaba, VR, or KO servo
 $\varnothing 3 \times 10$ tapping screw for Sanwa servo

Two types of servo savor springs, spring -48 and -52, are included.

(Spring -52 is stronger than spring -48. Use suitable spring for your purpose.)

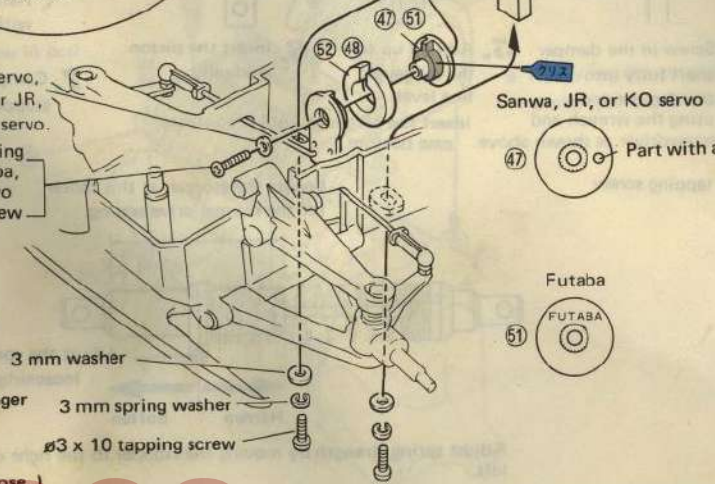

Removing the ball end

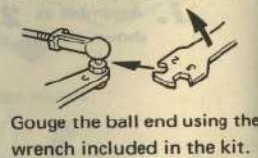

Adjusting rod length

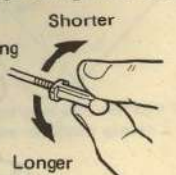

16 Speed controller assembly and adjustment

(Set the servo to receiver before beginning assembly or adjustment instructed on this page.
(See P. 2.)

Metallic part actual sizes used on P. 9



2 mm nut
... 1 pc



Free ball (B)
... 1 pc

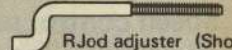

R.Jod adjuster (Short) ... 1 pc

Servo horn (Included in the proportional controller kit)

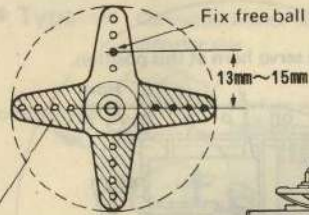

Holes on Servo Horn to be placed at the distance of 13mm to 15mm.

Remove the oblique portion.

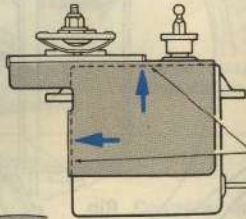

Press the servo toward the arrow, and affix to metal fittings tightly.

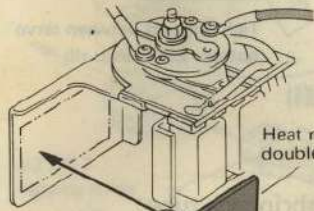

Heat resisting double face tape
Cut the tape into 35 mm length.

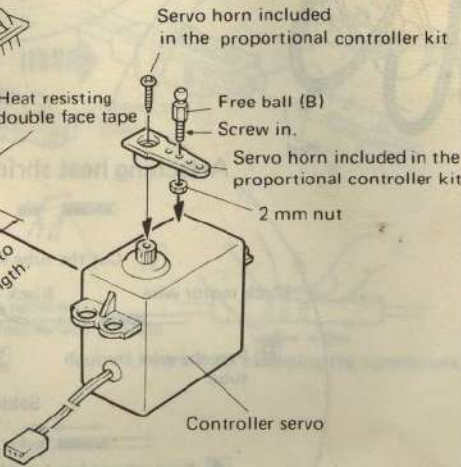

- Clean bonding area with thinner for use on plastic.
- Apply sufficient pressure the controller servo.
- Do not touch adhesive face after removing the backing paper.

Install in the order of 1 through 4.

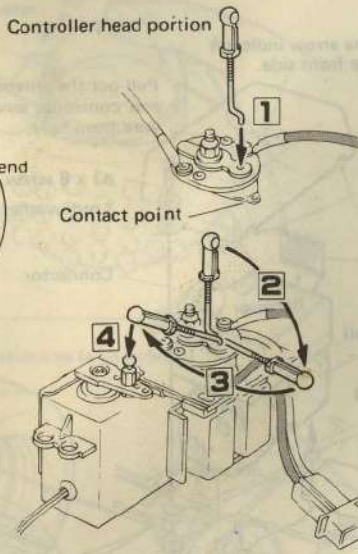

Insert the rod adjuster edge in the servo horn hole.

Screw in Part-41 adjusting to this length.

Controller neutral position Servo Neutral

When the controller head (contact point) is located within the neutral area, the servo horn is positioned as shown above.

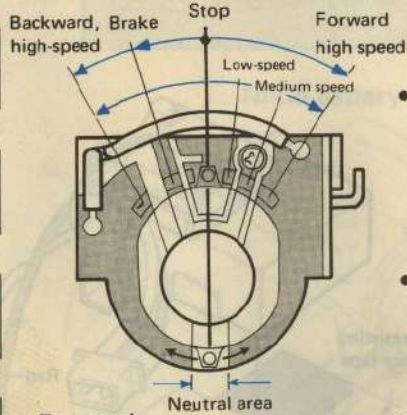

Switch position

- The controller may be damaged if it is used incorrectly. The controller has built-in resistors which may over-heat or burn if it is used only at low or medium speed ranges. Operate the model at its high-speed setting as much as possible.
- A large electric current is applied to the controller. The controller switch repeats turning ON and OFF the current, which shortens its life. Please understand that it is a kind of consumable part.
- Do not touch the controller soon after operation as its resistors may be hot.
- Defective controller installation, or faulty switch movement resulting from incorrect switch head location or wire placement may cause the resistors to over-heat and burn the bakelite electric component.
- Avoid the use of the controller in a closed mechanical box as it contains heat generating resistors.

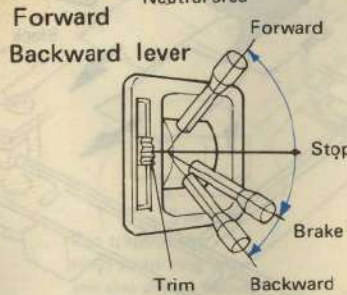

Stroke adjustment

Servo horn stroke differs by servo type. Perform a test to see if the switch arm moves all the way to its forward (high-speed) and backward (high-speed) positions by moving levers up and down. Adjust if the stroke is excessive or too small as shown on the right.

Perform stroke adjustment as follows (observe the order):

- 1 Disconnect the ball end.

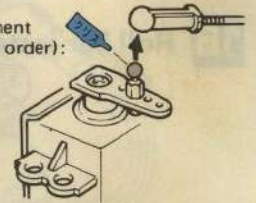

- 2 Change the hole holding free ball (B).

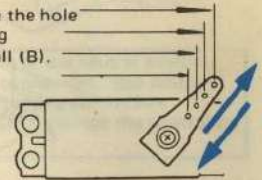

- 3 Adjust rod adjuster length and connect with free ball (B).

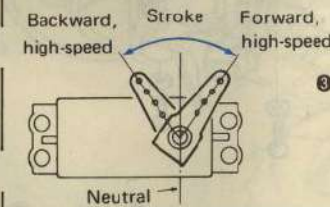
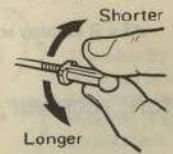

Placement of contact Point.

It is no use if contact point setting insufficient.

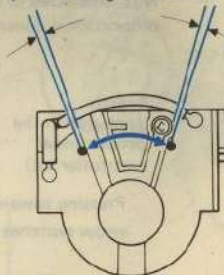

In case improper contact point setting done, remove hole position of servo horn toward 15mm side as illustrated.

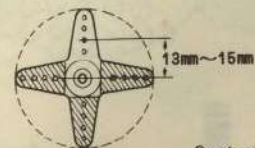

Contact point Setting to be firmly fixed as possible.

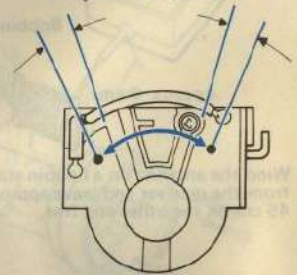

22 Driver and wheel assembly

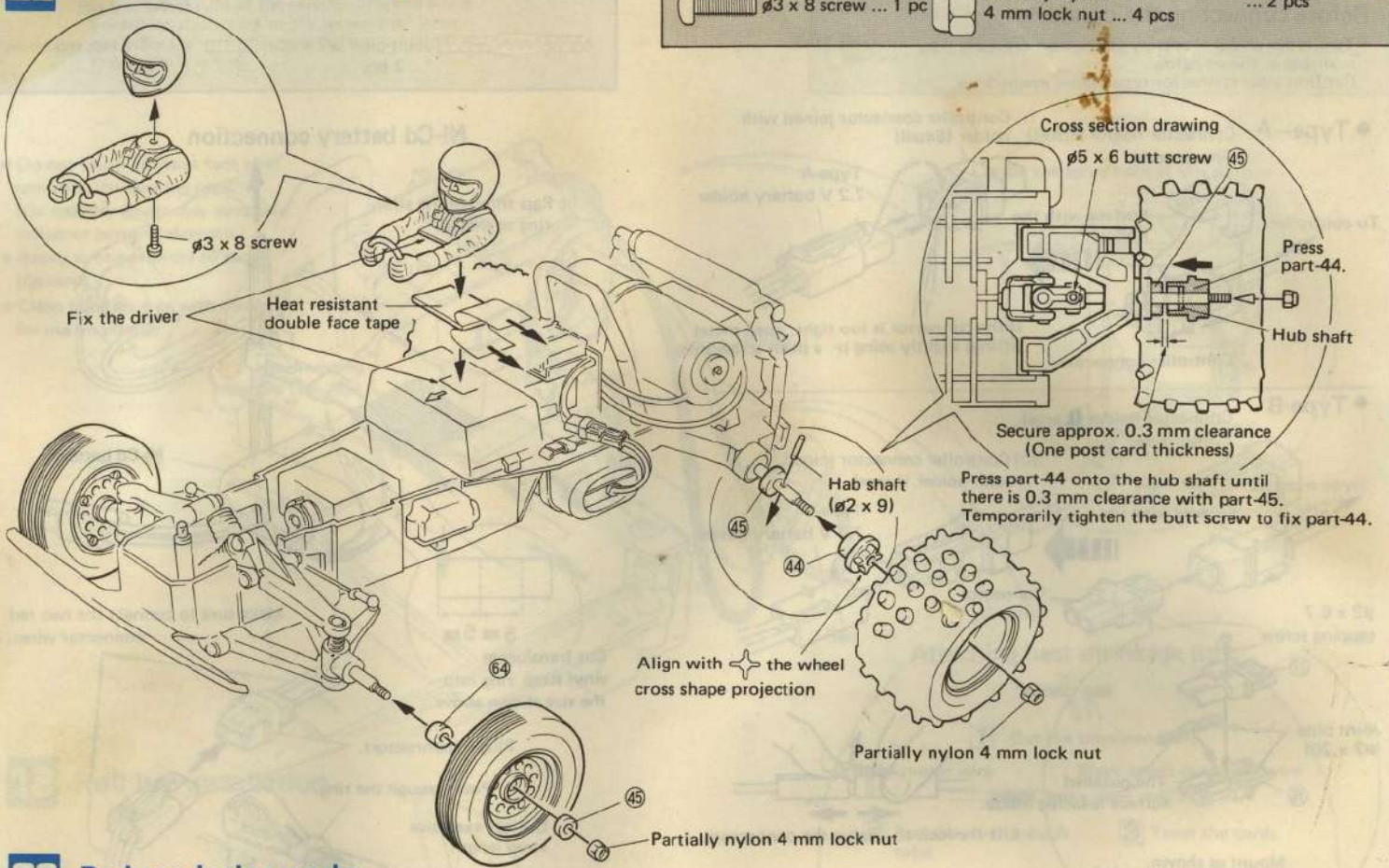

Metallic part actual sizes used on P. 12

$\phi 3 \times 8$ screw ... 1 pc

Partially nylon
4 mm lock nut ... 4 pcs

$\phi 2 \times 9$ hub shaft
... 2 pcs

23 Body and wing works

* Use a gimlet or drill to make required holes.

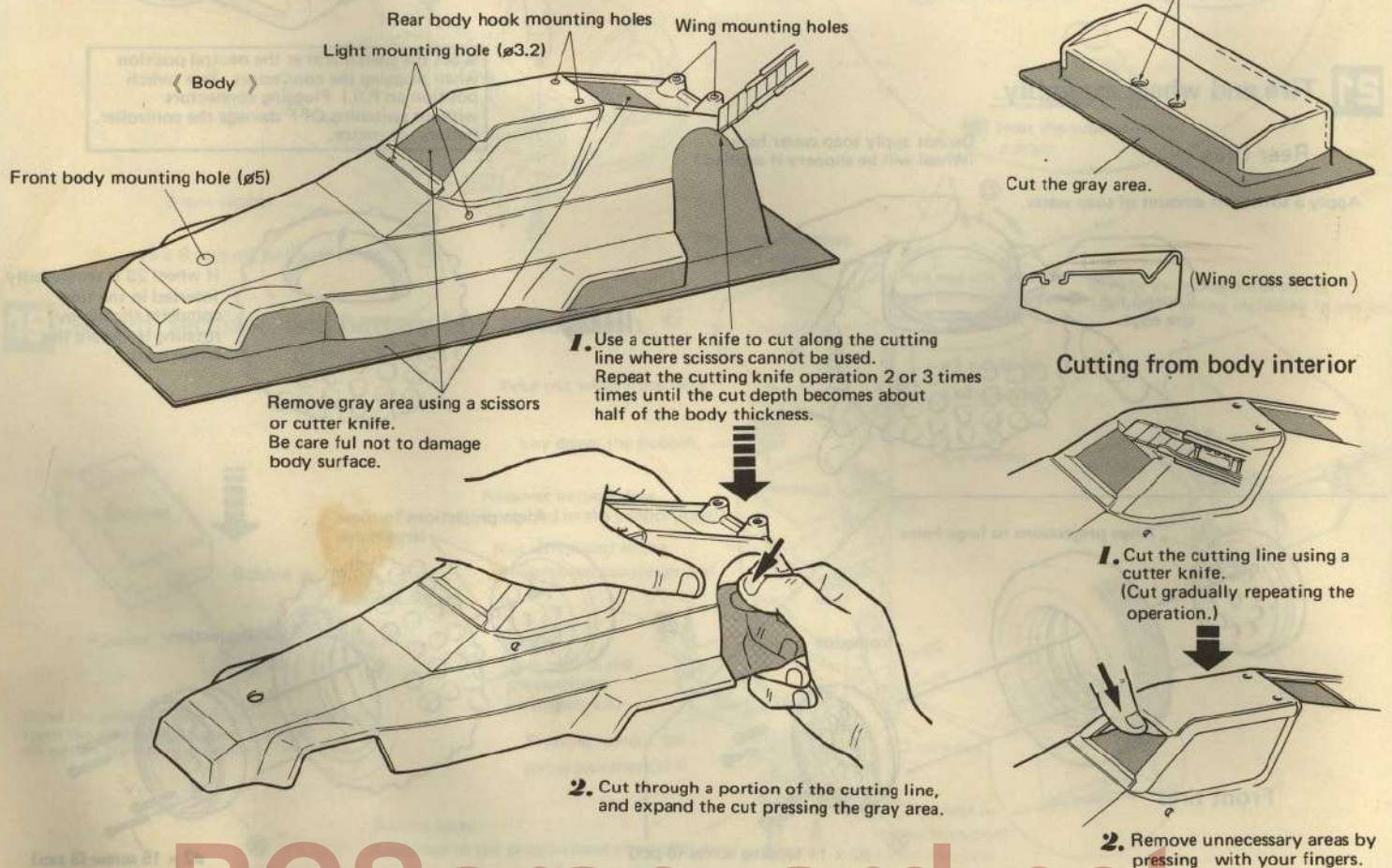

Metallic part actual sizes used on P. 13

φ3 x 6 screw ... 4 pcs

φ2 x 9 tapping screw ... 2 pcs

3 mm nut ... 6 pcs

Snap pin ... 1 pc

φ3 x 8 screw ... 2 pcs

3 mm washer ... 4 pcs

24 Painting

- Clean dirt and oil with soapy water before painting.
- Coat the body inside with paint for polycarbonate or lacquer (other than plastic use type).
- Paint the body exterior following the picture on the package as an example.
- Apply masking tape (scotch tape) on windows and roll bars. (Remove masking tape after dry.)

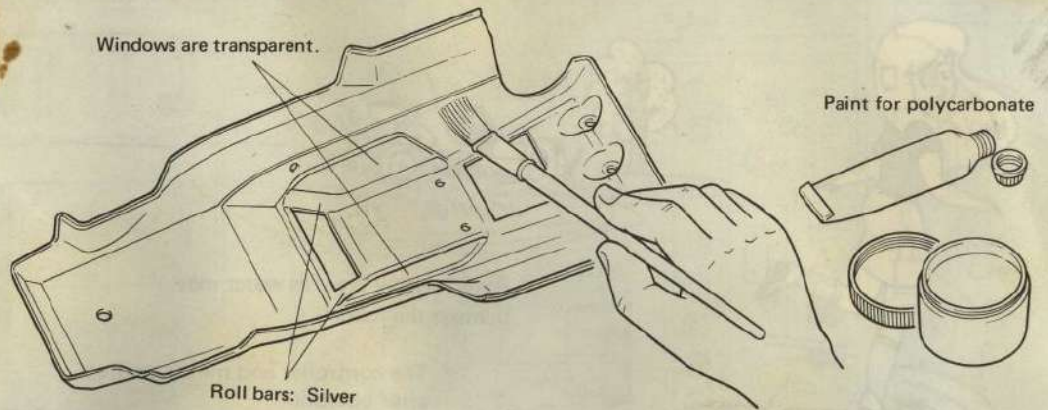

25 Body assembly

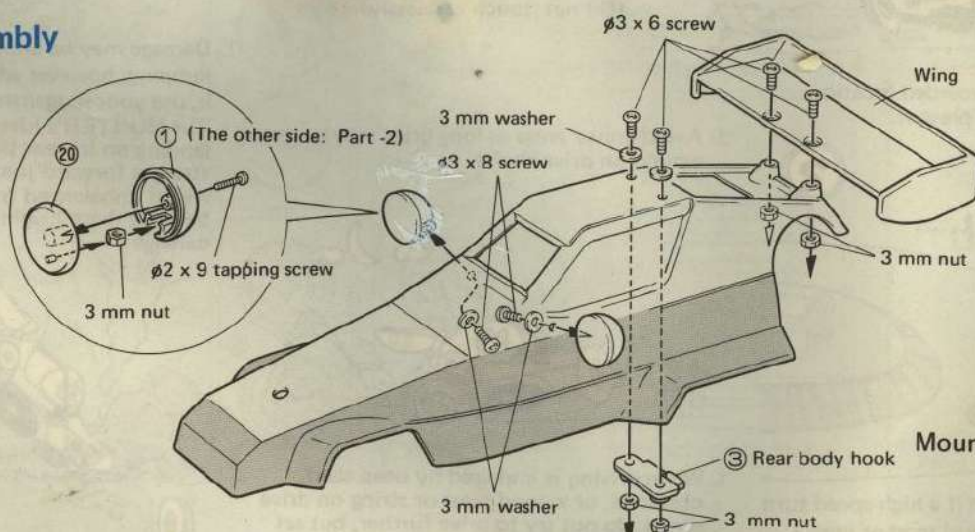

Mounting the antenna pipe

Tie this area so that wire does not fall into the pipe.

About 5 cm is out of the pipe

Antenna pipe

Press antenna pipe into this chassis hole after passing the wire through pipe.

26 Body installation

Install in the order of 1 to 3

Snap pin

First hook on the roll bar.

Adhere the net seal from inside.

Adhere marks with reference to the drawing of the picture on the case

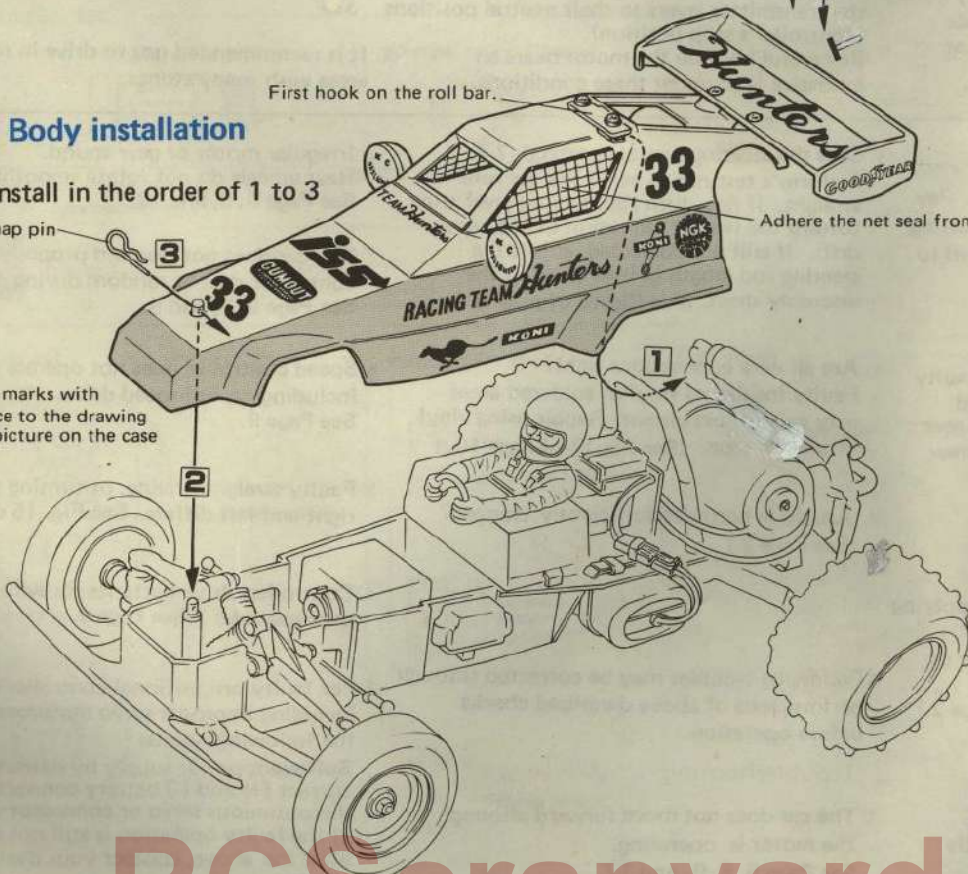

Pass the wire through the hole. The wire is stretched so that it will not be tangle with the tire.



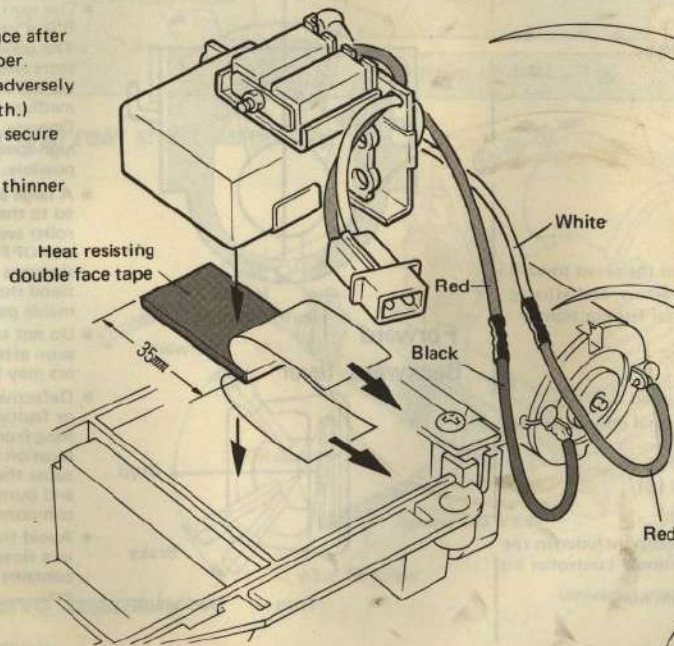

17 Speed control servo installation

● If HUNTER runs in the reverse direction when controller stick is set to the forward position, the wire connection between the motor and controller is wrong.

- Do not touch adhesive face after removing the backing paper. (Oil on your finger may adversely influence bonding strength.)
- Apply strong pressure to secure the servo.
- Clean bonding area with thinner for use on plastic.





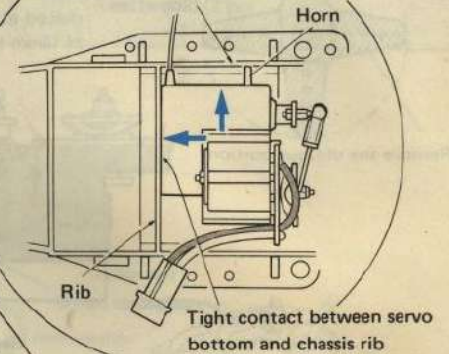

Metallic part actual sizes used on P. 10

	∅3 x 8 tapping screw ... 2 pcs		3 mm washer ... 4 pcs
	∅3 x 8 screw ... 2 pcs		3 mm nut ... 2 pcs

Locate the servo horn at this position.

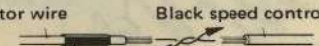

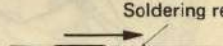
Attaching heat shrinkage tube

- 1 Cut the tube into half.

- 2 Pass the wire through tube.

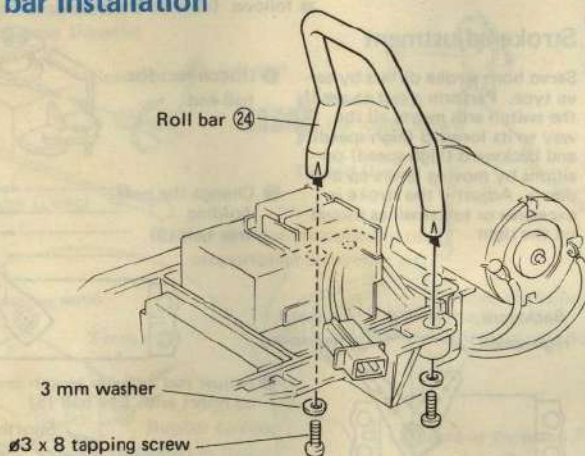
- 3 Twist the cords.

- 4 Cover the twisted cord area with the tube.

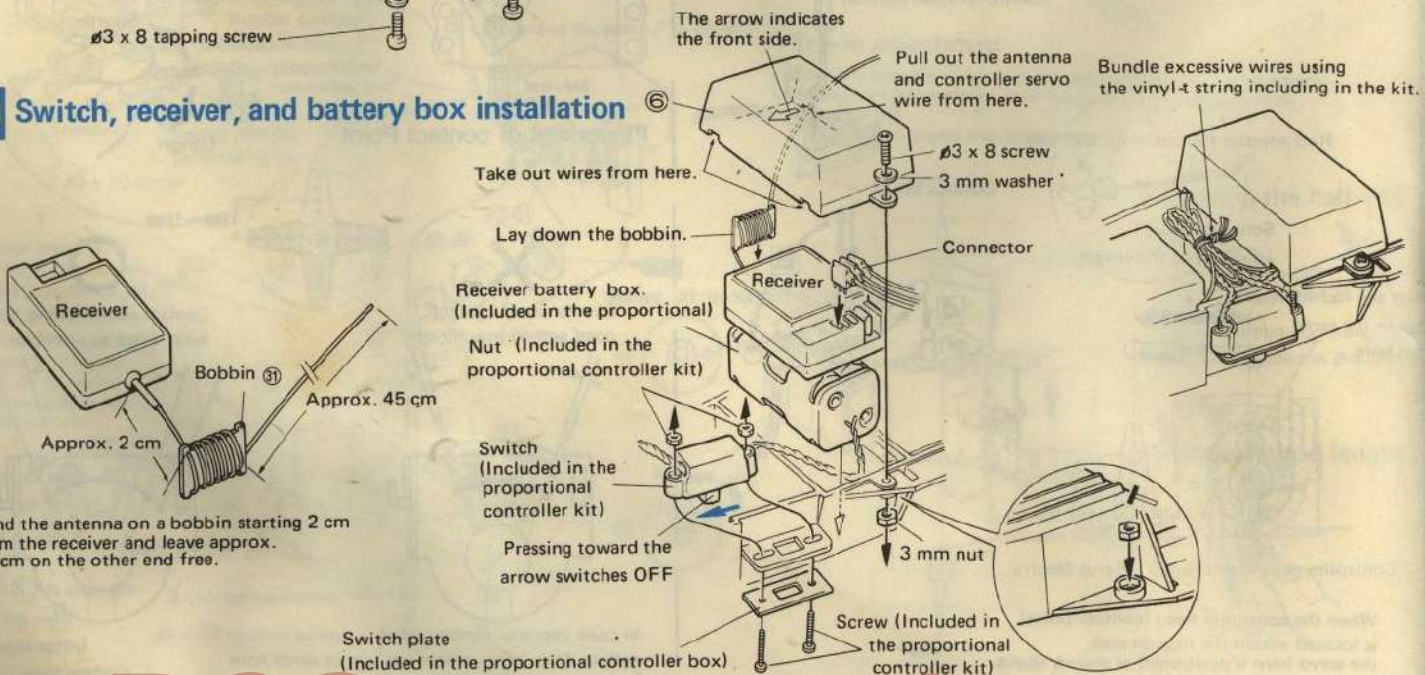
- 5 Heat the tube using a dryer.

18 Roll bar installation



19 Switch, receiver, and battery box installation



Wind the antenna on a bobbin starting 2 cm from the receiver and leave approx. 45 cm on the other end free.

20 Ni-Cd battery placement

Before connecting the connector

※ Two types of 7.2 V battery connectors are available as shown below. Confirm your connector type before connection.

• Type-A

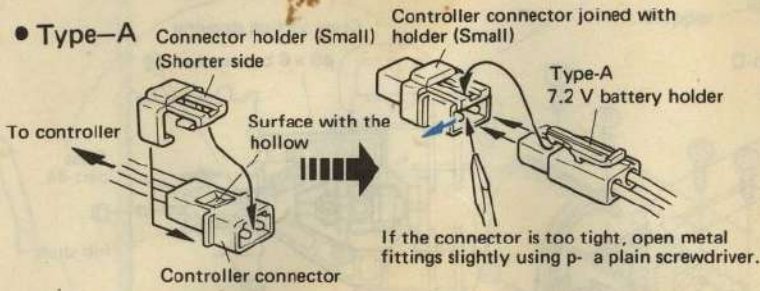

• Type-B

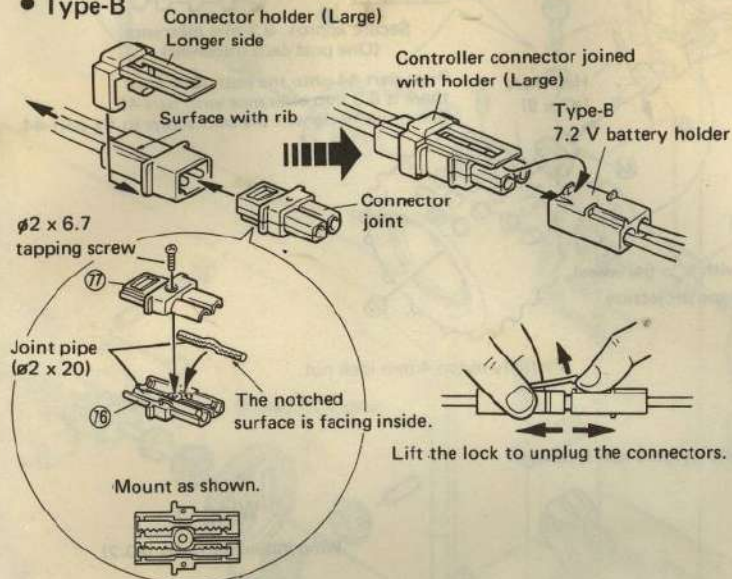

Metallic part sizes used in P. 11

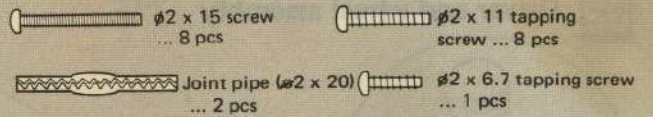

Ni-Cd battery connection

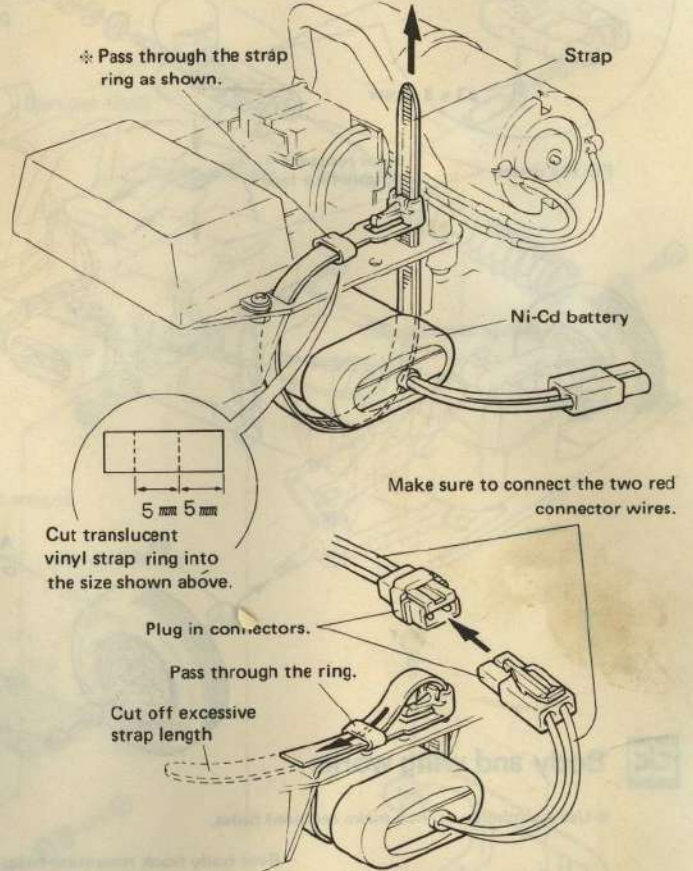

※ Set the switch arm at the neutral position when plugging the connectors. (see switch position on P.9.) Plugging connectors without switching OFF damage the controller, battery, or motor.

21 Tire and wheel assembly

Rear tires

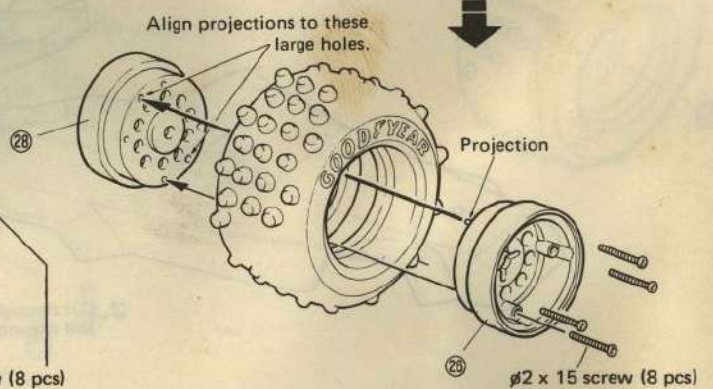
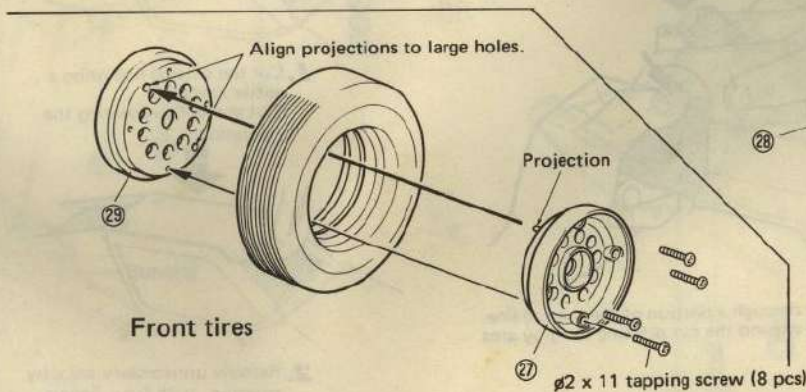
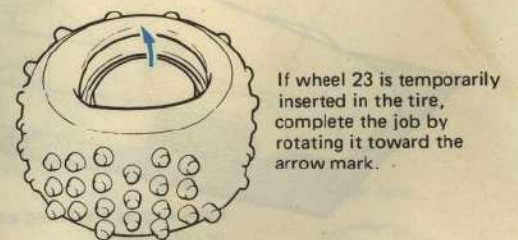
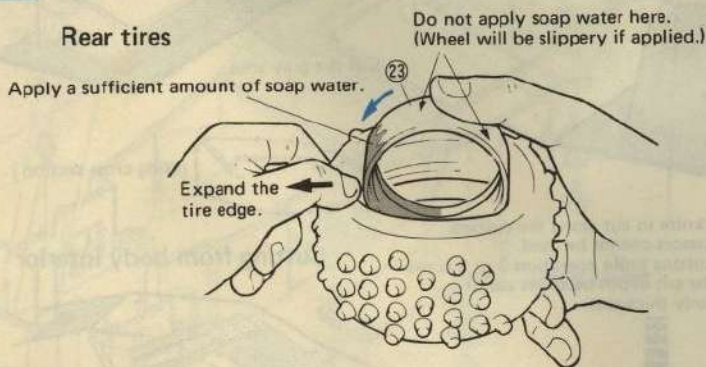

《HANDLING PRECAUTIONS》

The HUNTER is designed as a high-speed off-road racing car. Be careful while handling and operating this model.



- ① Do not operate at a crowded location or where children are present.



- ③ Avoid sloppy areas as water may damage the model.

- ④ The controller and motor are hot after operation. Be careful not to burn yourself. (Do not touch carelessly)

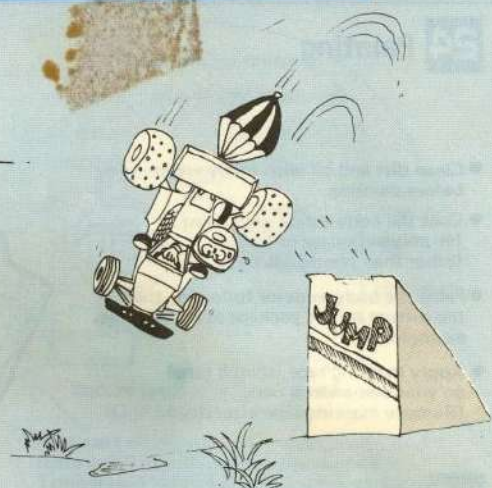

- ⑦ Damage may be anticipated if the car jumping, however when some races require it, use your judgement. The HUNTER's ideal weight balance enables landing on its rear tires after taking a level straight forward jump at full-speed. Avoid unbalanced front tire landings because these heighten the possibility of damage.

- ⑤ Avoid grassy areas as long grass may become wound on drive shafts.

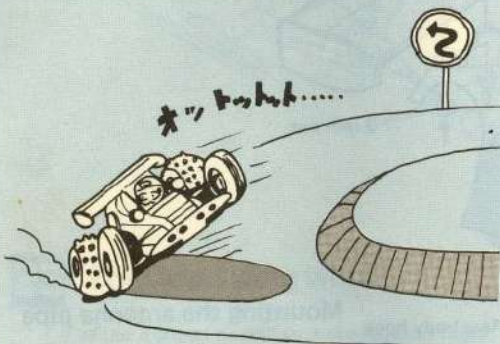

- ② The car may overturn if a high-speed turn is performed on a paved road or grassy lawn. Make sure to remember the basic principle for cornering, slow in and fast out



- ⑥ When driving is impaired by deep sand, obstacles, or wound grass or string on drive shafts, do not try to drive further, but set the transmitter levers to their neutral positions (controller's stop position). Be careful because the motor bears an excessive load under these conditions.

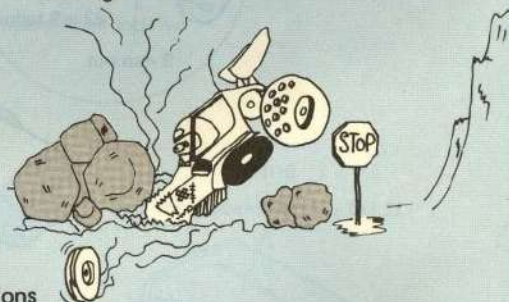

- ⑧ It is recommended not to drive in rough areas with many stones.

Checks before driving

- ① Check all screws and nuts for tightness. Pay special attention to screws and nuts securing the suspension, and butt screws attached to the universal joint.

- ② Check gears for correct engagement. Faulty pinion gear engagement due to loosened motor securing screws may cause idler gear damage. Check the pinion gear butt screw for correct tightness. (See Page 6.)

- ③ Are proportional controller batteries supplying sufficient power?
Receiver battery life is shorter than that of the transmitter, and early battery replacement is recommended. (See Page 2.)

- ④ Does the controller operate correctly?
Make sure that the controller is correctly adjusted. (See Page 9.)

- ⑤ Does the steering operate correctly?
Perform a test run to see if the car runs straight. If not, turn the steering lever trim toward the reverse direction of the car's drift. If still not corrected, adjust the steering rod length as instructed in the assembly sheet. (See Fig.15 of page 8.)

- ⑥ Are all wire connections tight?
Faulty insulating vinyl or soldered areas may cause short circuit. Repair using vinyl insulating tape. (See Fig.17 of Page 10.)

- ⑦ Are drive batteries sufficiently charged?
(See Page 2.)

- Following troubles may be corrected through performance of above described checks before operation.

Troubleshooting

- ① The car does not move forward although the motor is operating.
See Page 5, 6, 9, and 12.

- ② Irregular motor or gear sound.
Rear wheels do not rotate smoothly.
See Page 5, 6, and 12.

- ③ The car does not respond properly to control or runs at random during driving.
See Page 2, 8, and 9.

- ④ Speed controller does not operate correctly including no full-speed drive.
See Page 9.

- ⑤ Faulty straight driving, or turning to the right and left differs. See Fig. 15 of Page 8.

- ⑥ Controller, drive batteries, or wires are over-heated. See Page 9.

- ⑦ For faulty proportional controller operation including improper servo movement, check the following points:
Sufficient power supply by batteries, correct (+) and (-) battery connections, and discontinuous servo or connector wires. If the faulty operation is still not corrected after the above, contact your dealer for repair.

PART LIST

Body x 1

Chassis x 1

ABS parts ① x 1

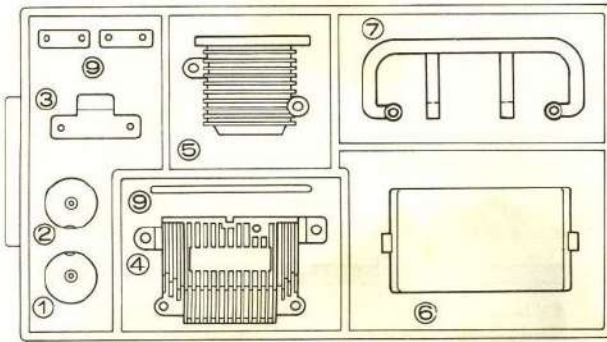

ABS parts ② x 1

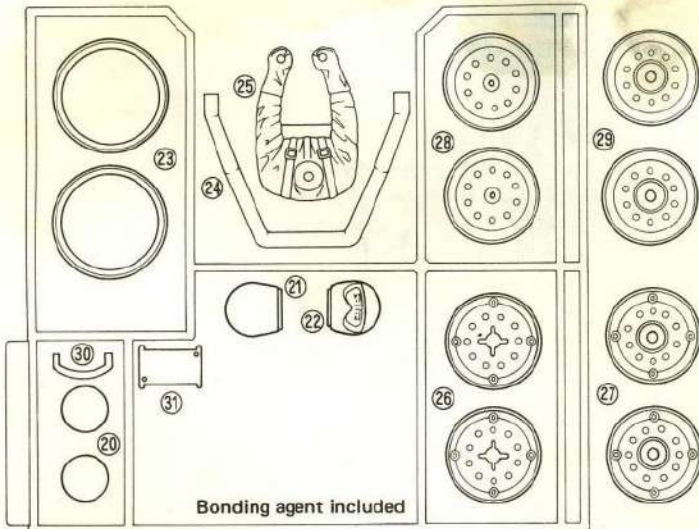

Reinforced nylon parts (A) x 1

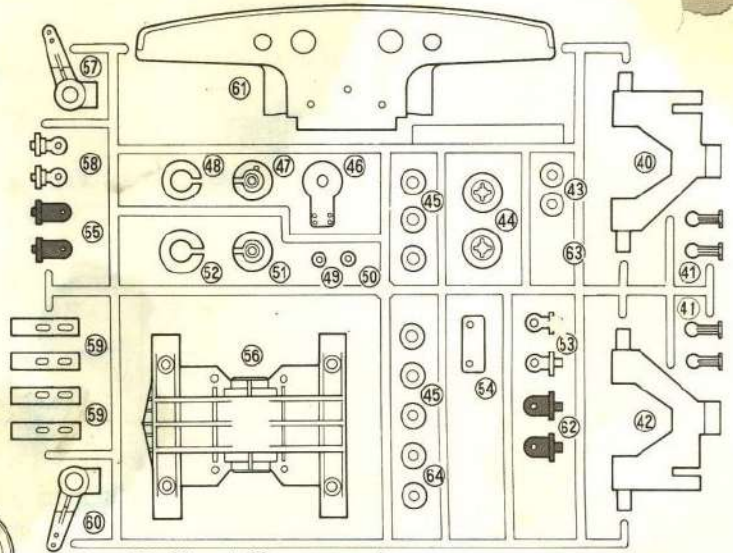

Part -55, -62, and -63 are not used.

Reinforced nylon parts (B) x 1

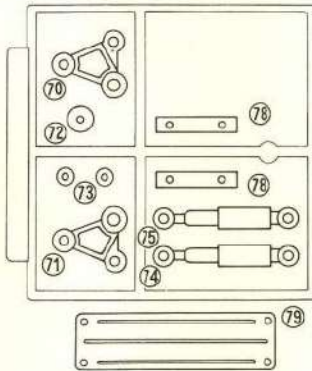

Front suspension set

Upper arm x 2

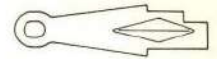

Lower arm x 2

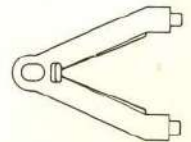

Front suspension mount x 1

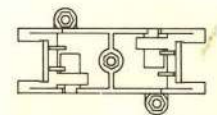

Damper set

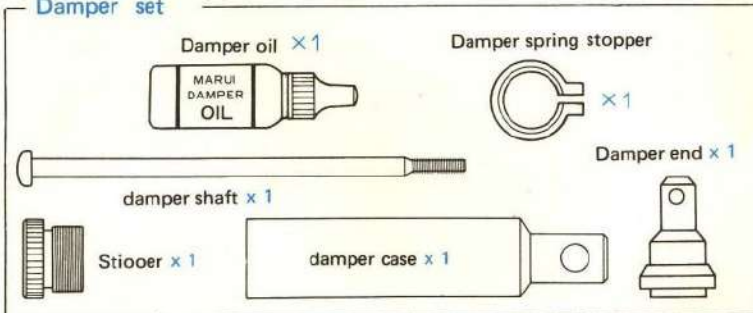

Universal joint x 2

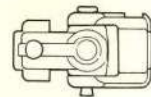

Motor mount x 1

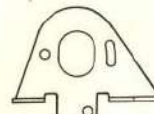

With sponge cushion

MABUCHI RS-540 motor x 1

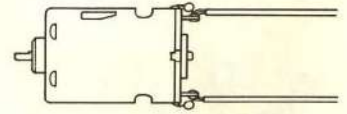

Gear set

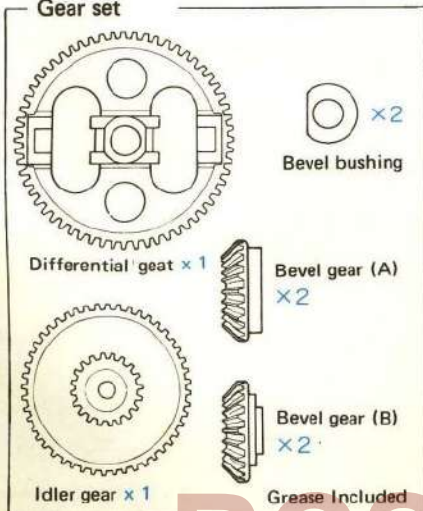

Pinion gear set

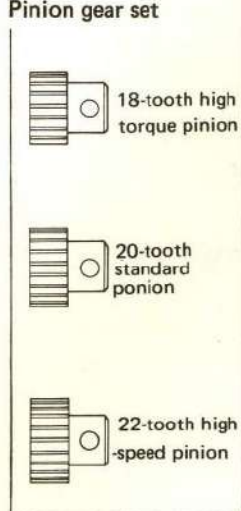

Controller

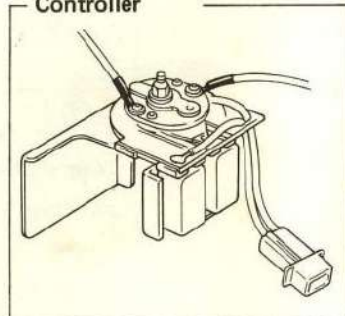

Heat resistant double face tape x 1

Antenna pipe x 1

Strap x 2

Front tires x 2



Rear tires x 2

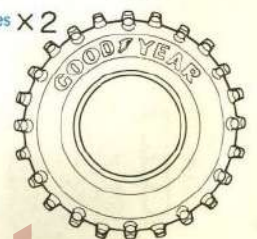

PART LIST

● Some types of screws and nuts are included excessively for spare part use.

(“φ3” in figures represents “3 mm diameter”)

Metallic part set

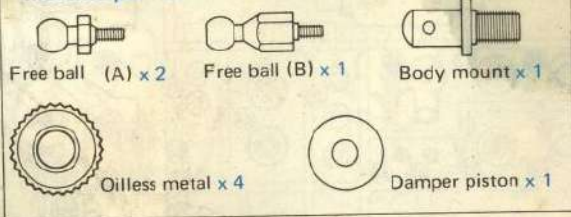

Nut set

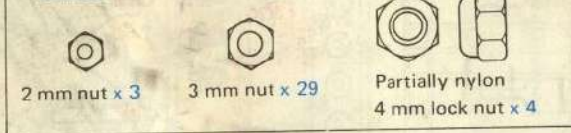

Spacer set

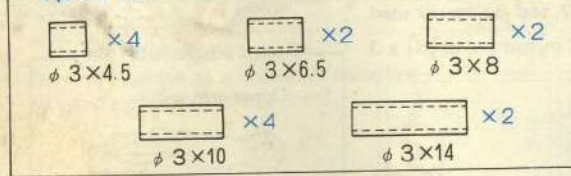

★ Spare parts may be purchased separately.

Washer set

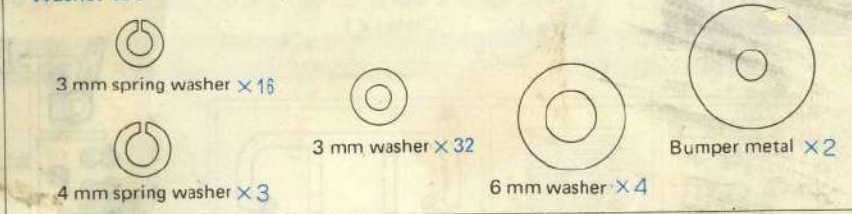

Screw set

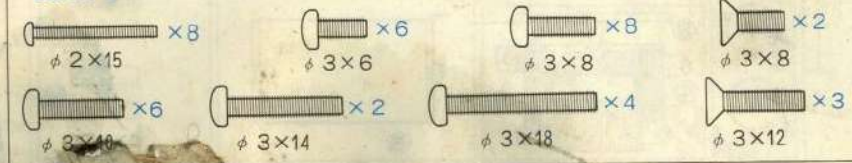

Tapping screw set

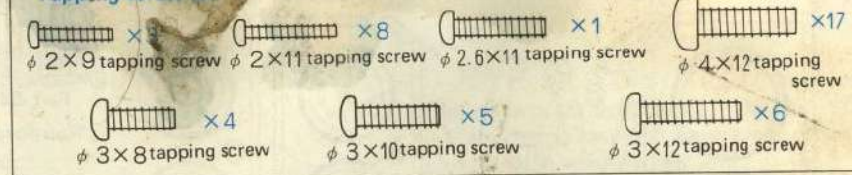

Spring set



Set-A

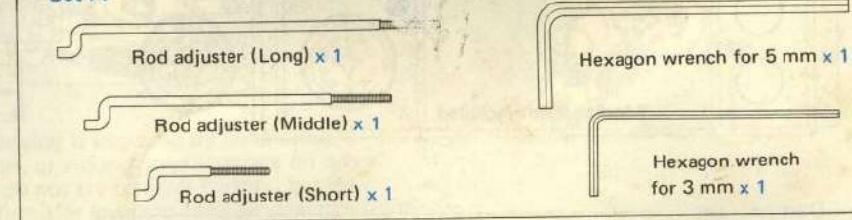

Set-B

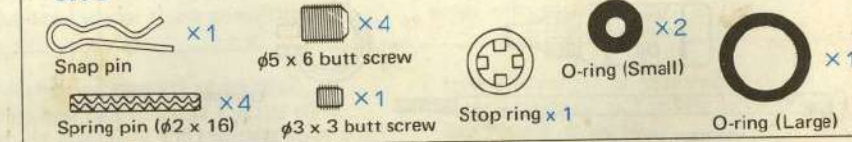

Shaft set

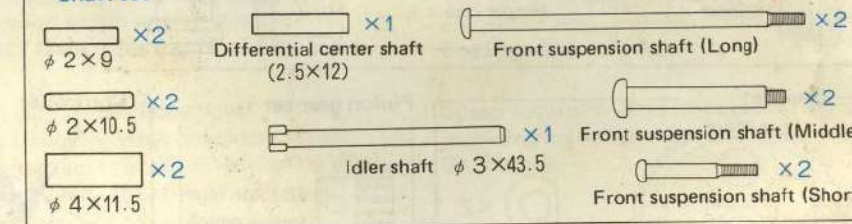

Main shaft set

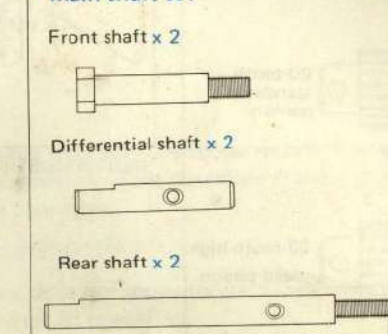

Connector set

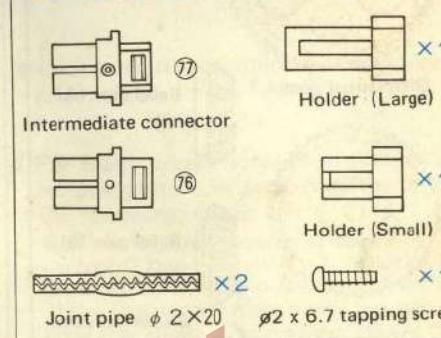

1/10 SCALE ELECTRIC R/C CAR ASSEMBLE KIT THE HUNTER COMPOSITION

