

# GALAXY-RS

## 1/10 SCALE RADIO CONTROL OFF-ROAD RACING BUGGY

READY TO ASSEMBLE RADIO CONTROL OFF-ROAD RACING CAR MODEL KIT/REQUIRES TWO CHANNEL, TWO SERVO CONTROL EQUIPMENT AND 7.2V RACING PACK Ni-Cd BATTERY/INCLUDES MABUCHI RS540S POWERFUL MOTOR

With RS-540S High Speed Motor

1/10 Size, Electrically Powered, Radio Controlled Buggy Racing Model

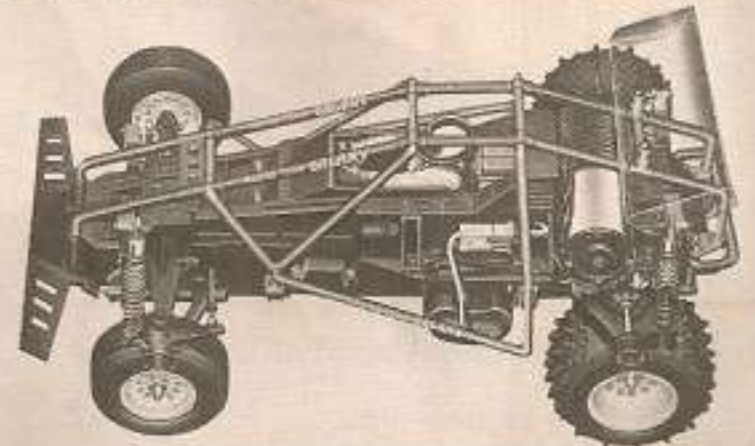

### MODELLING SKILLS HELPFUL IF UNDER 10 YEARS OF AGE.

DIFFERENTIAL GEAR DRIVE SYSTEM.  
CHANGEABLE PINION GEAR RATIOS.  
STRAIGHT RIBBED FRONT RUBBER TIRES.  
WART PATTERN REAR RUBBER TIRES.  
DURABLE REAR WING.  
ADJUSTABLE 4 OIL FILLED SHOCK ABSORBERS.  
ASSEMBLED SPEED CONTROLLER.

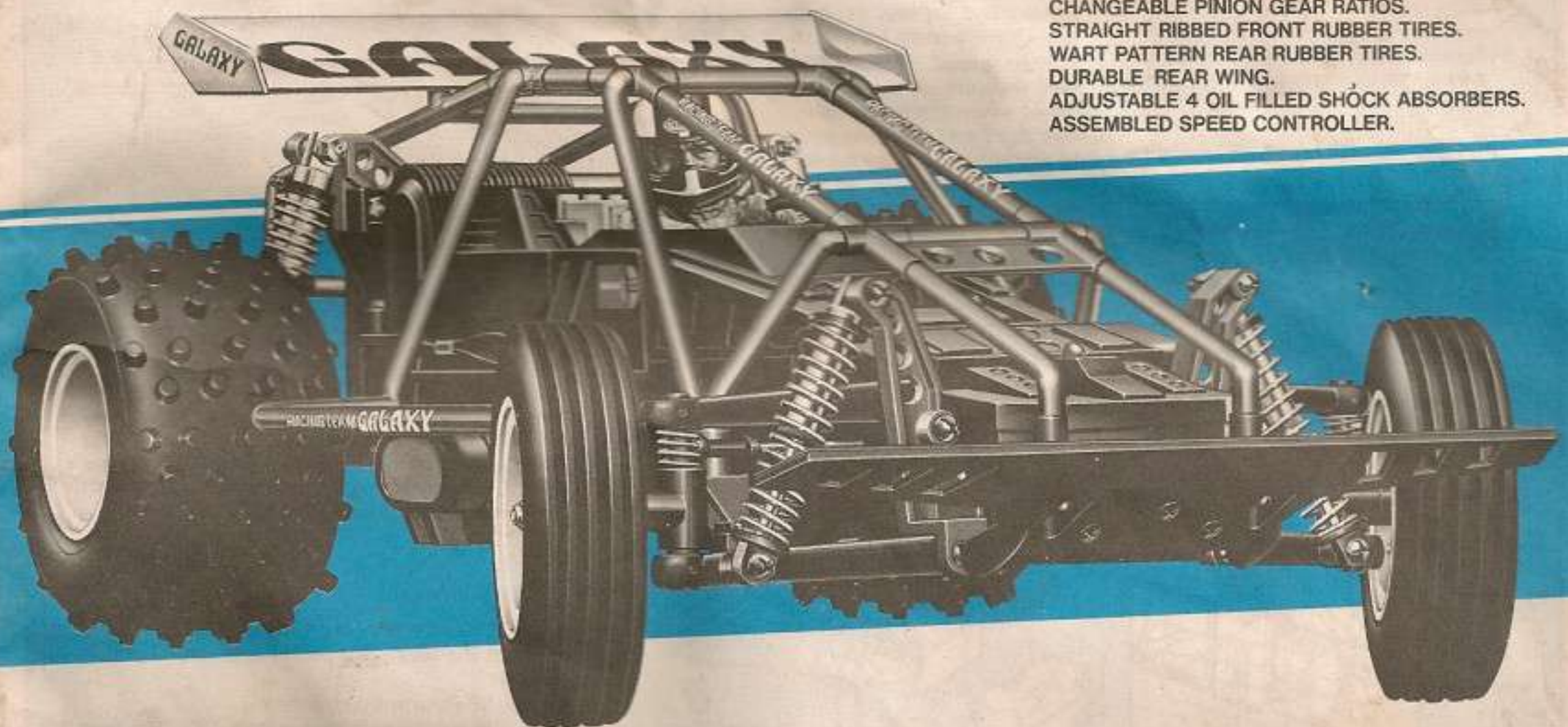

Tokyo Marui Plastic Model Co., Ltd.

## HIGH PERFORMANCE R/C OFF-ROAD RACING CAR

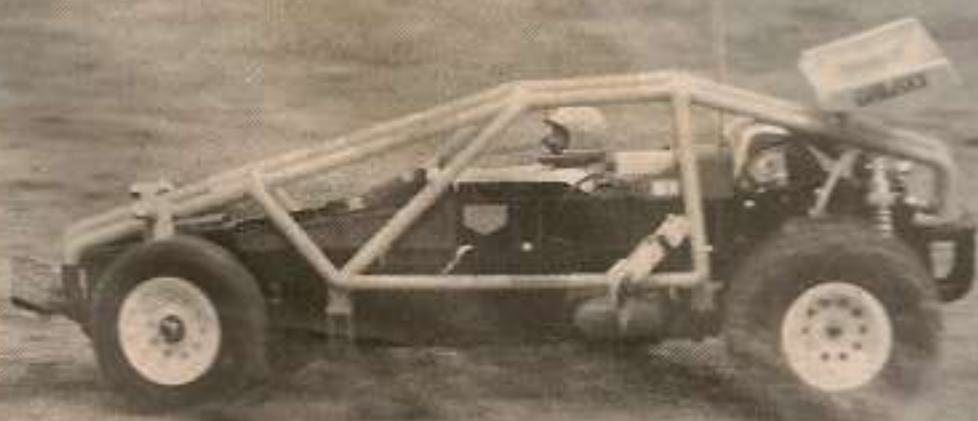

[RCScrapyard.net](http://RCScrapyard.net)



## < Parts not included in the kit >

- 2-channel 2-servo proportional controller

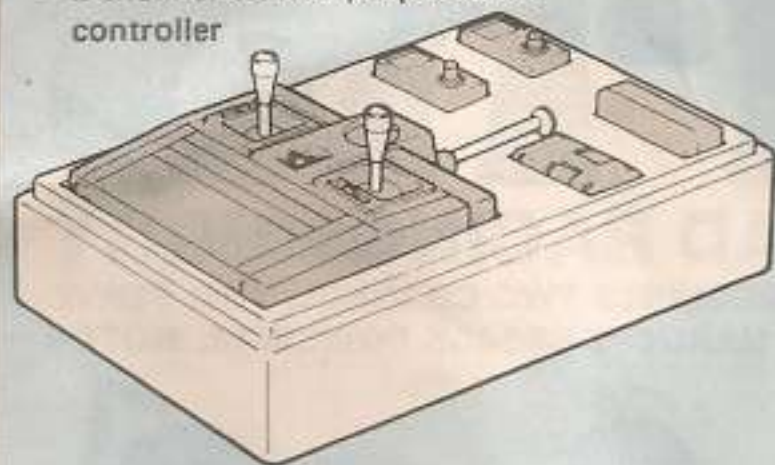

• Batteries for the proportional controller

Majority of general type 2-channel unit is acceptable. Please be careful as some types are not suitable for this model. For those who are going to purchase a controller, the following models are recommended:  
 FUTABA: ATTACK, MAGNUM  
 K.O.: FX-II EX-II  
 J.P: BEAT 2  
 SANWA: NEW DASH S

Unplug the battery connector after use.

- Special battery charger

Marui 8.4V battery recharger (recharger must be purchased separately)

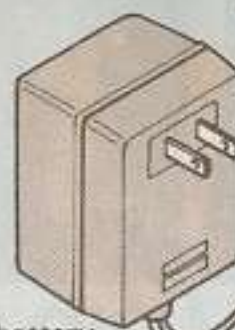

- Battery for driving:

A Nickel Cadmium battery of either a 6, 7.2, or 8.4V is needed.



Marui 8.4 V Ni-Cd super racing battery (battery must be purchased separately)

6 to 8.4V Ni-Cd battery can be used to power the car. This battery can be recharged over 300 times. One type of recharger uses 100V household current to charge the battery in 4 to 16 hours. The other, a quick type recharger, uses a car's 12V cigarette lighter as a power source to charge the battery in 15 to 20 minutes.

## < Tools required for assembly >

- ⊕ Only phillips type screwdrivers are shown in actual sizes.

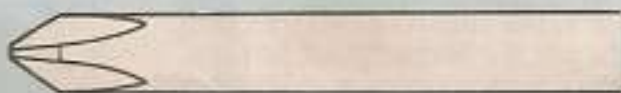

+ Screwdriver (Large) for  $\phi 3$  screws and  $\phi 3$  tapping screws

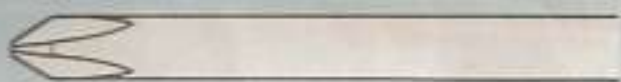

+ Screwdriver (Middle) for damper shaft,  $\phi 2$  screws, and  $\phi 2.6$  tapping screws

This kit includes many tapping screws. Use the proper screwdriver for tapping screws. Use adequate torque to tighten screws. Release turning pressure on the screwdriver when the screw becomes tight and does not rotate any more. Be careful not to damage screws by applying too much torque.

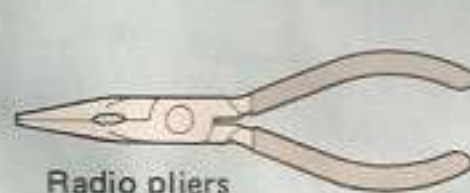

Radio pliers

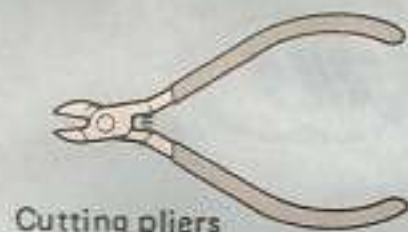

Cutting pliers

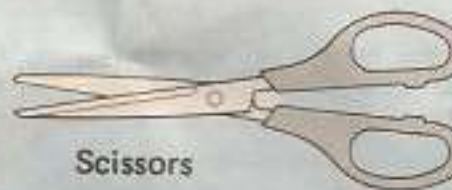

Scissors



Cutter



Plain screwdriver (Middle)



Small hammer

## < Radio control unit >

- ③ Extend the antenna

- ① Insert batteries

- ⑥ Set trim levers at their neutral positions

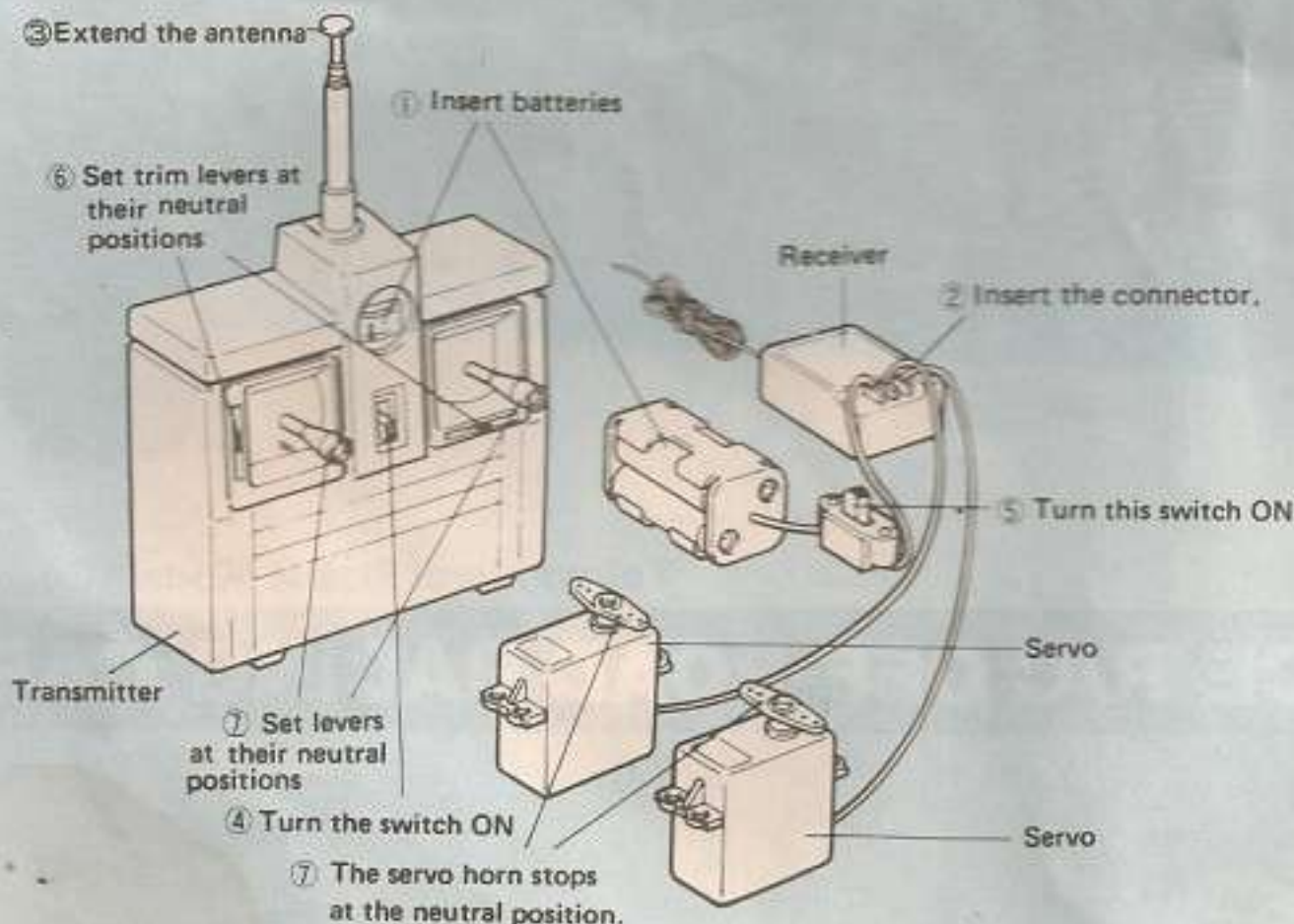

- ⑦ Set levers at their neutral positions

- ④ Turn the switch ON

- ⑦ The servo horn stops at the neutral position.

This model uses a 2-channel 2-servo digital method radio control mechanism. Any maker's brand may be used. However, please note some types of controllers have more than 3 channels, and they cannot be utilized for this kit's receiver and servo.

- Check the 2-channel proportional controller for correct operations as follows:

- ① Insert batteries in the transmitter and receiver.
- ② Connect the receiver's power and servo leads to the receiver.
- ③ Extend the transmitter antenna.
- ④ Turn ON the transmitter switch. (Always turn ON the transmitter switch.)
- ⑤ Turn ON the receiver switch.
- ⑥ Set the trim levers at their neutral positions.
- ⑦ Set the levers at their neutral positions. (The servo horns should stop at their neutral positions.)
- ⑧ Check servos operation by moving the levers.
- ⑨ Turn OFF the receiver first and then the transmitter when the test is complete. Refer to the radio control equipment instructions for further details.

## ★ Read the following instructions carefully before assembly

- Read the entire instructions carefully and understand the structure well before starting assembly. This ensures smooth assembly.
- A < grease > mark indicates a portion where the grease included in the kit must be applied. Similarly, a small hammer should be used when the < hammer > mark appears.
- The screws and washers to be used for assembly are shown in actual sizes. Ensure the use of correct components by comparing their actual sizes according to the chart before assembly.

- Some screws, nuts, and washers may be left over as more than required numbers are included in this kit. Use them as spare parts.

- Thoroughly remove plastic part burrs using a cutter knife.

\* Strengthened nylon part burrs must be completely removed as they may impair driving performance. (Be careful not to cut your fingers with a cutter knife.)

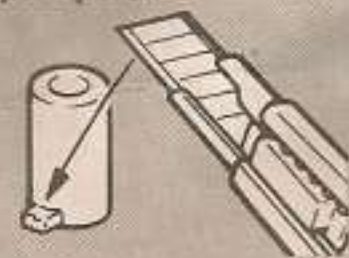



◀Metallic part actual sizes used on P. 3▶

φ 3 x 8 flat-head screw ..... 2 pcs

2 mm nut ..... 2 pcs

Front shaft ..... 2 pcs

Front suspension shaft (Long) ..... 2 pcs

φ 3 x 12 tapping screw ..... 2 pcs

3 mm nut ..... 5 pcs

Free ball (A) .... 2 pcs

φ 2 x 16 Spring pin ..... 2 pcs

3 mm spring washer ..... 4 pcs

3 mm washer ..... 4 pcs

φ 3 x 8 screw ..... 3 pcs

φ 3 x 10 spacer ..... 4 pcs

## 1 Under guard and front suspension mount assembly

• For 7.2 V battery:

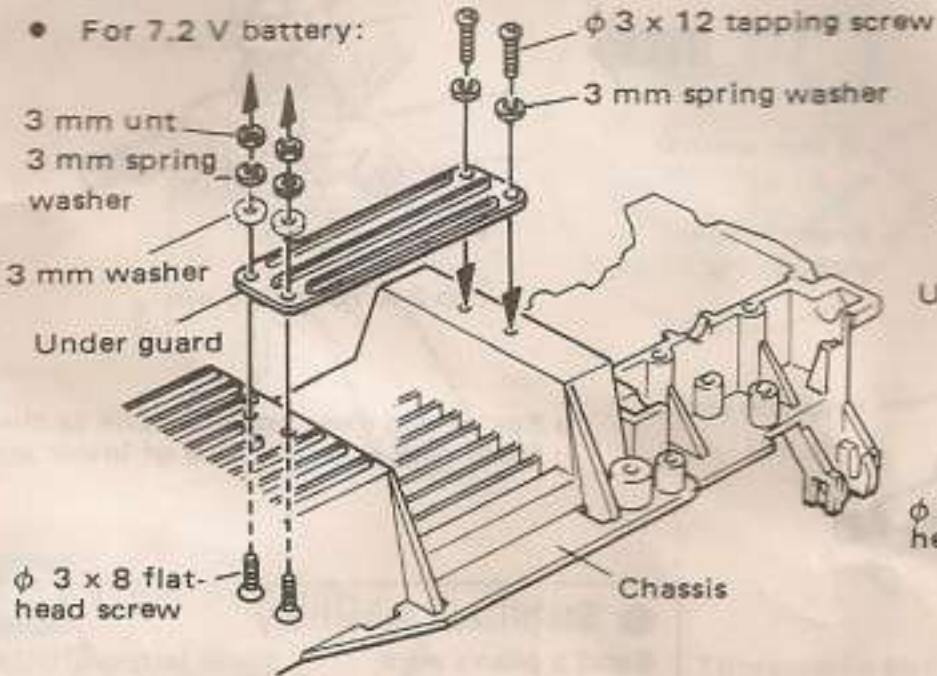

• For 6 V battery : Install parts 9 as shown.

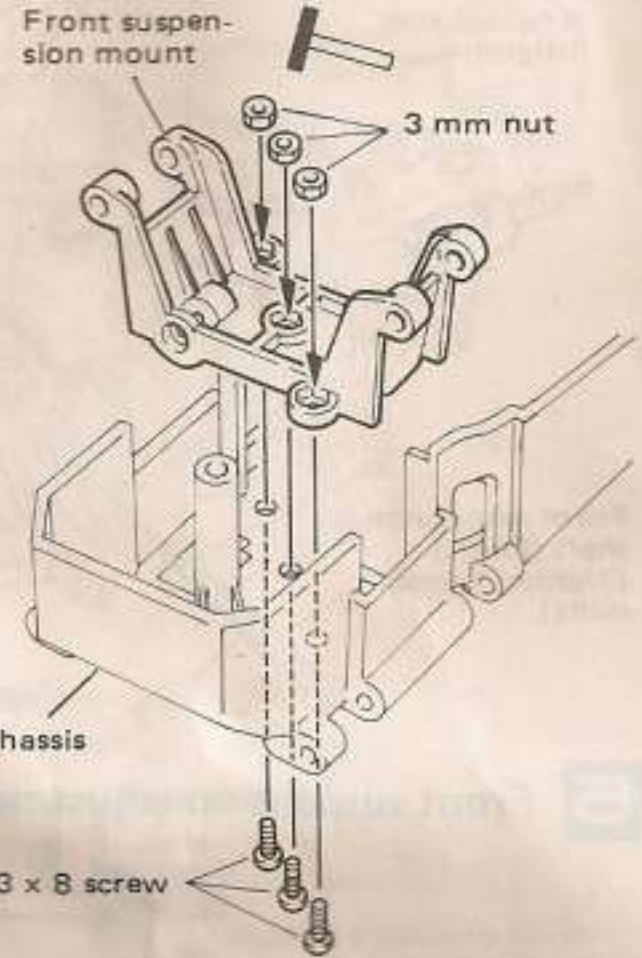
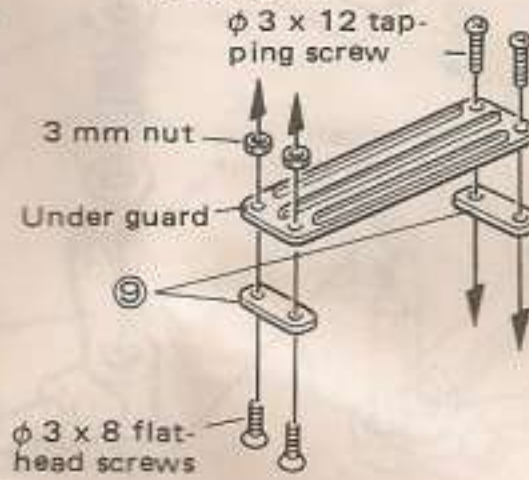

## 2 Lower arm assembly

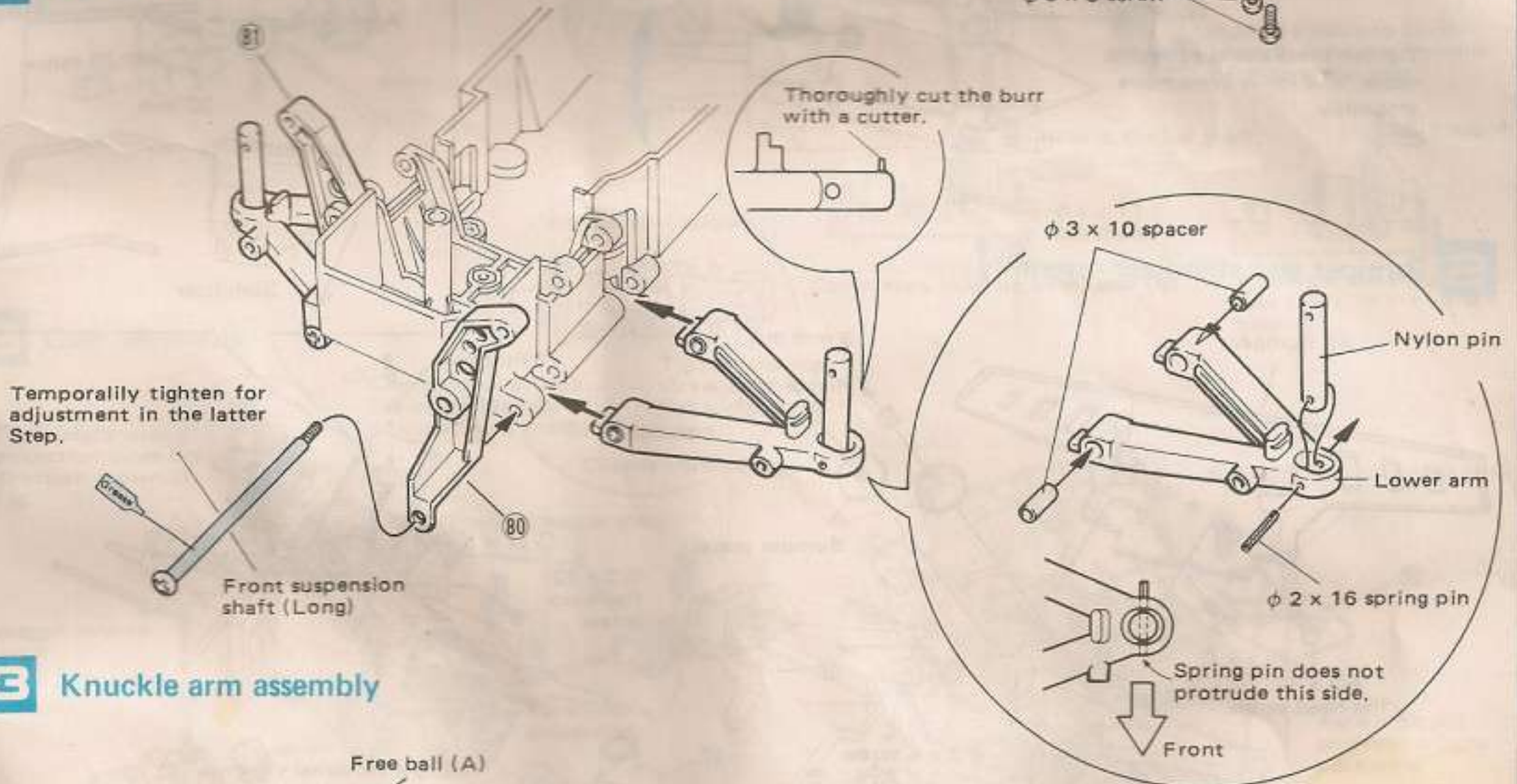

## 3 Knuckle arm assembly

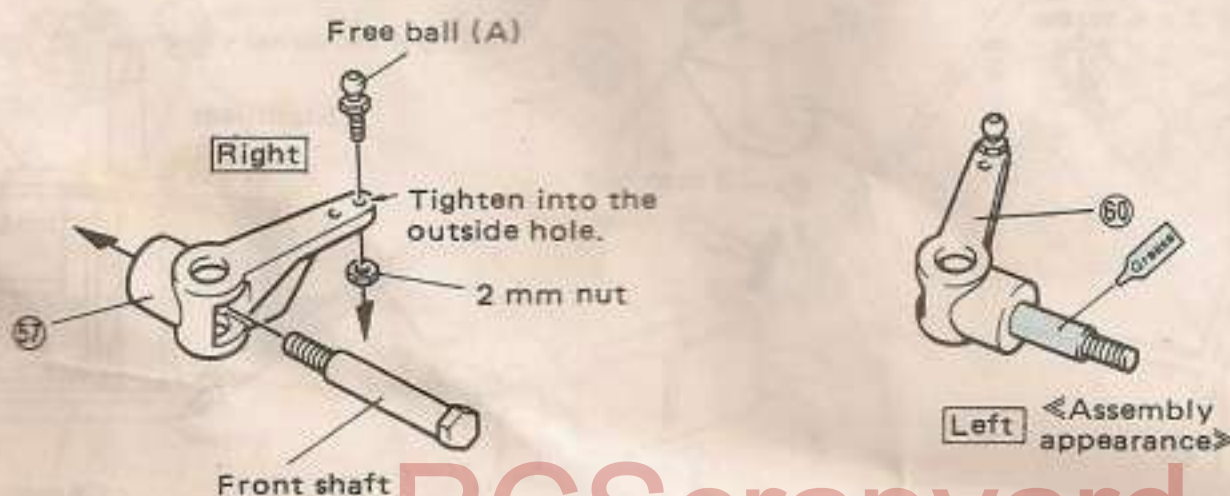



←Metallic part actual sizes used on P. 4→

φ 3 x 6 screw ..... 2 pcs

φ 3 x 12 flat-head screw ..... 3 pcs

φ 2 x 16 spring pin ..... 2 pcs

Partially nylon 4 mm locknut ..... 2 pcs

3 mm nut ..... 5 pcs

6 mm washer ..... 4 pcs

Bumper metal ..... 2 pcs

Piano wire

Front suspension shaft (short) ..... 2 pcs

Front suspension spring ..... 2 pcs

## 4 Upper arm assembly

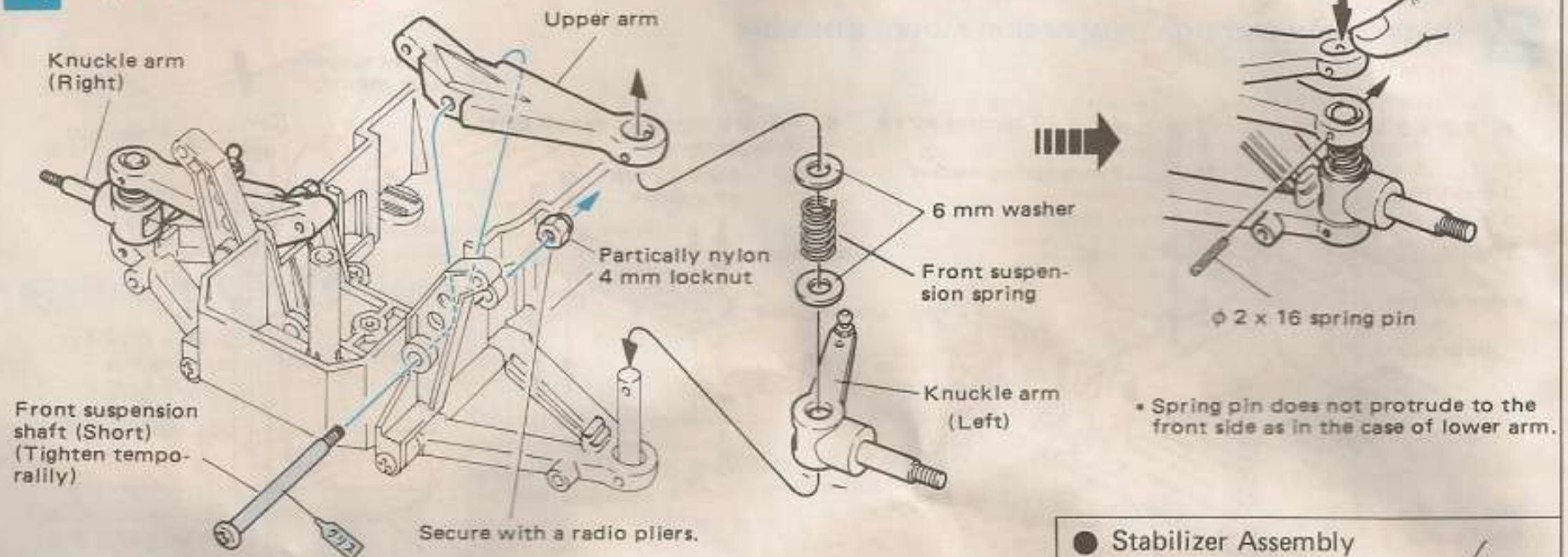

## 5 Front suspension adjustment

Tighten these shafts such that upper and lower arms move smoothly.

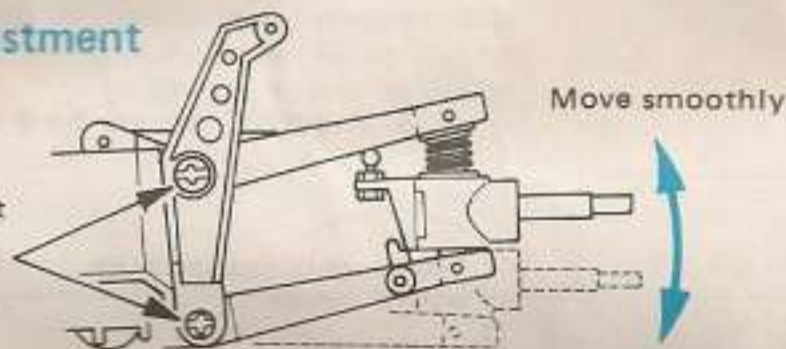

## 6 Bumper and stabilizer assembly

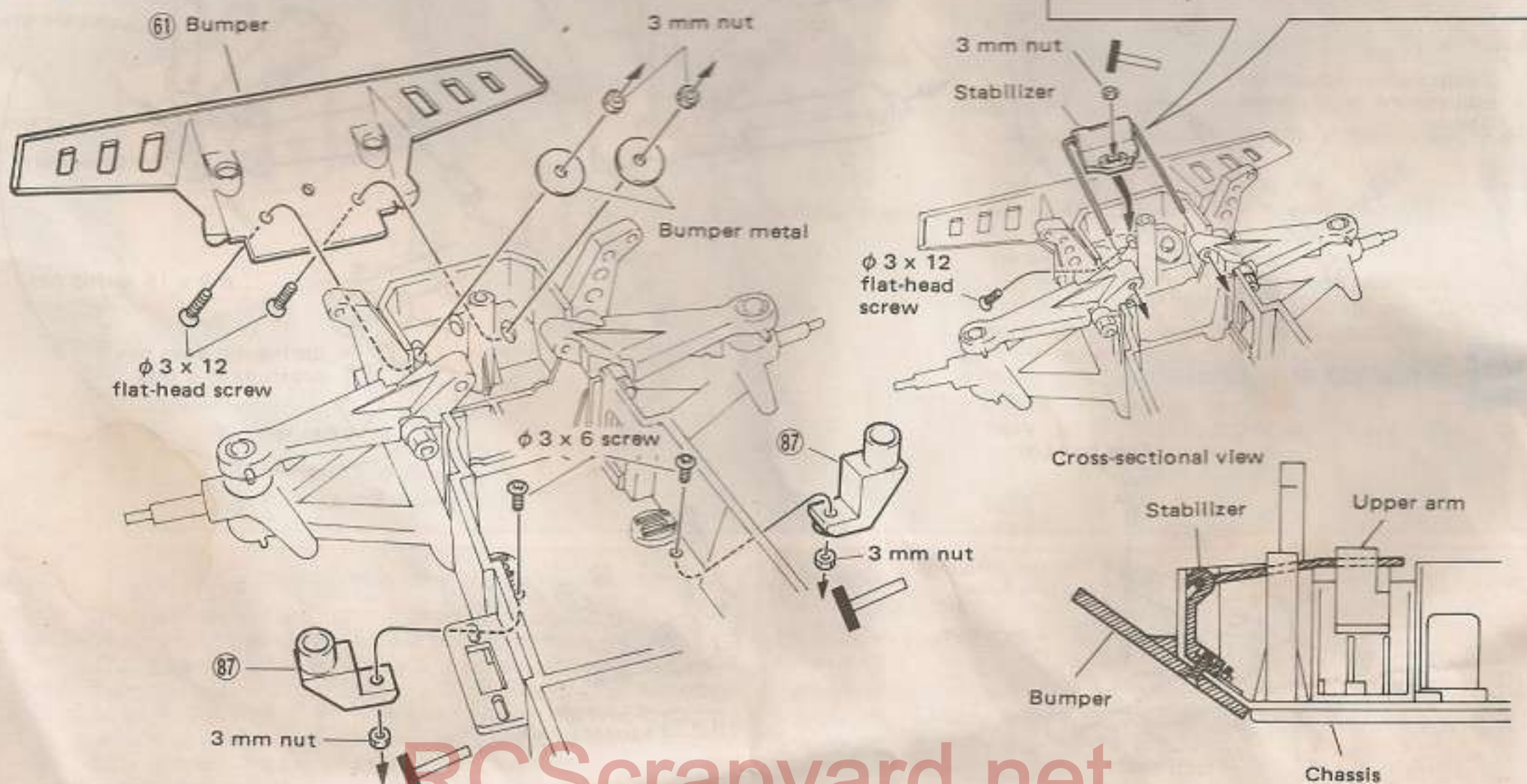

### ● Stabilizer Assembly





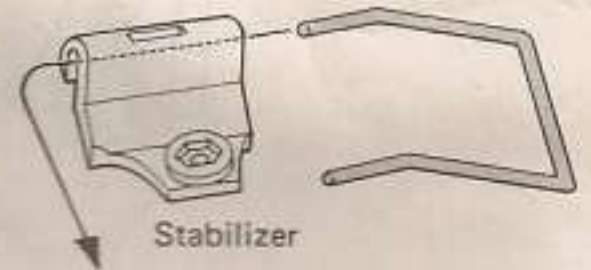
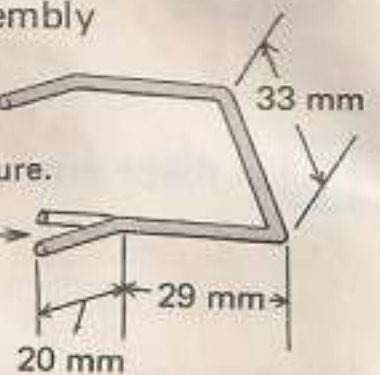

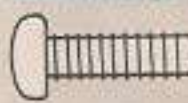

Bend a piano wire, at a bench or other convenient area, as shown in the Figure.

Approx. 3 mm

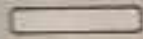
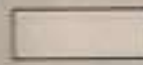
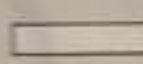

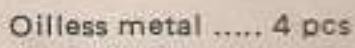

<Metallic part actual sizes used on P. 5>

-   $\phi 4 \times 12$  tapping screw ..... 8 pcs
-  3 mm nut ..... 1 pc
-   $\phi 5 \times 6$  butt screw ..... 2 pcs
-   $\phi 2 \times 10.5$  bushing pin ..... 2 pcs
-   $\phi 4 \times 11.5$  bevel shaft ..... 2 pcs
-   $\phi 2.5 \times 12$  differential center shaft ..... 1 pc
-  Differential shaft ..... 2 pcs
-  Bevel bushing (Plastic) ..... 2 pcs
-  Oilless metal ..... 4 pcs
-  Bevel gear (A) ..... 2 pcs (Plastic)
-  Bevel gear (B) ..... 2 pcs
-  Universal joint ..... 2 pcs

## 7 Driving the metal and bonding the driver



## 8 Gear assembly

### <Differential shaft assembly>

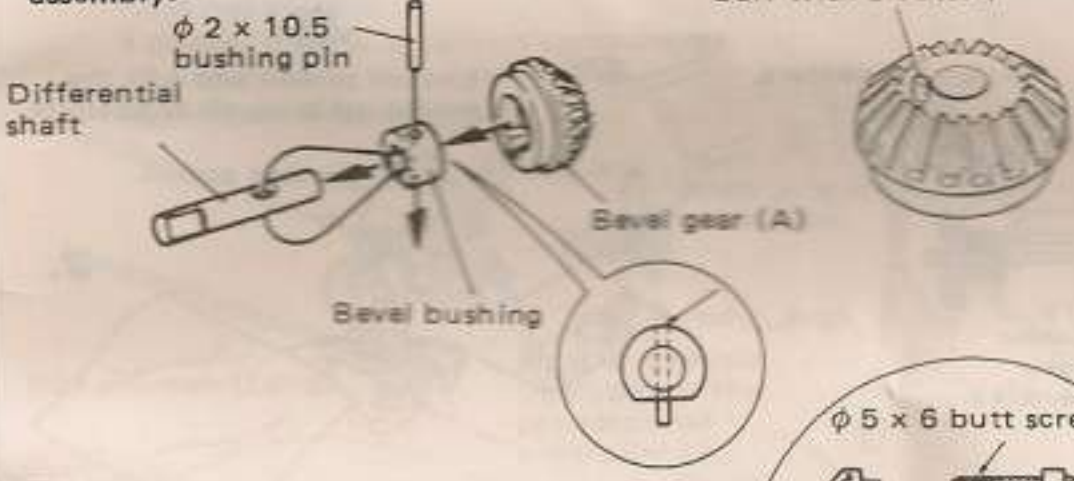

### <Differential gear assembly>

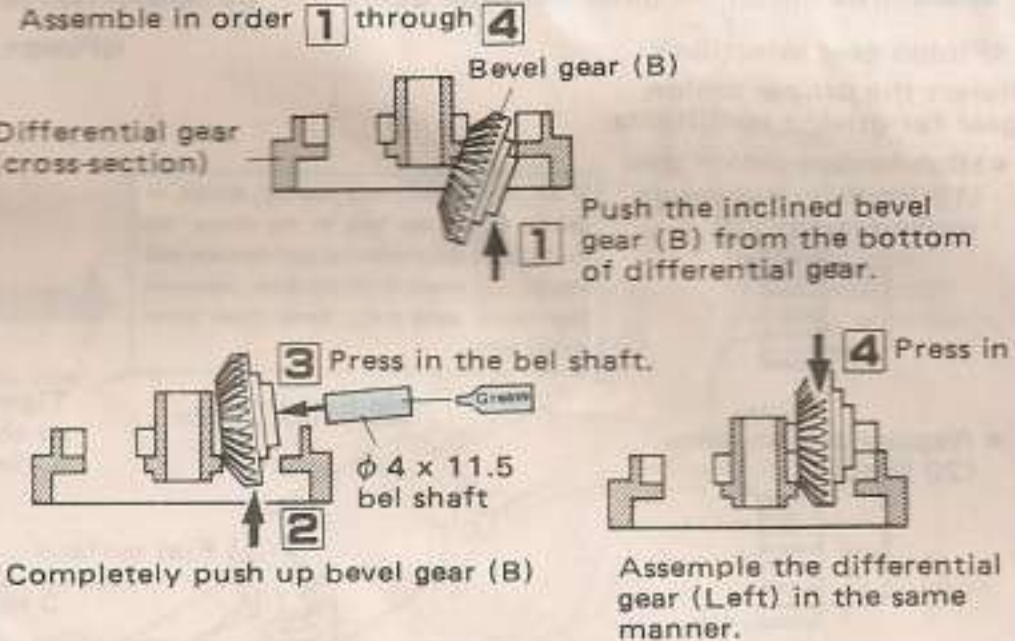

## 9 Gear assembly

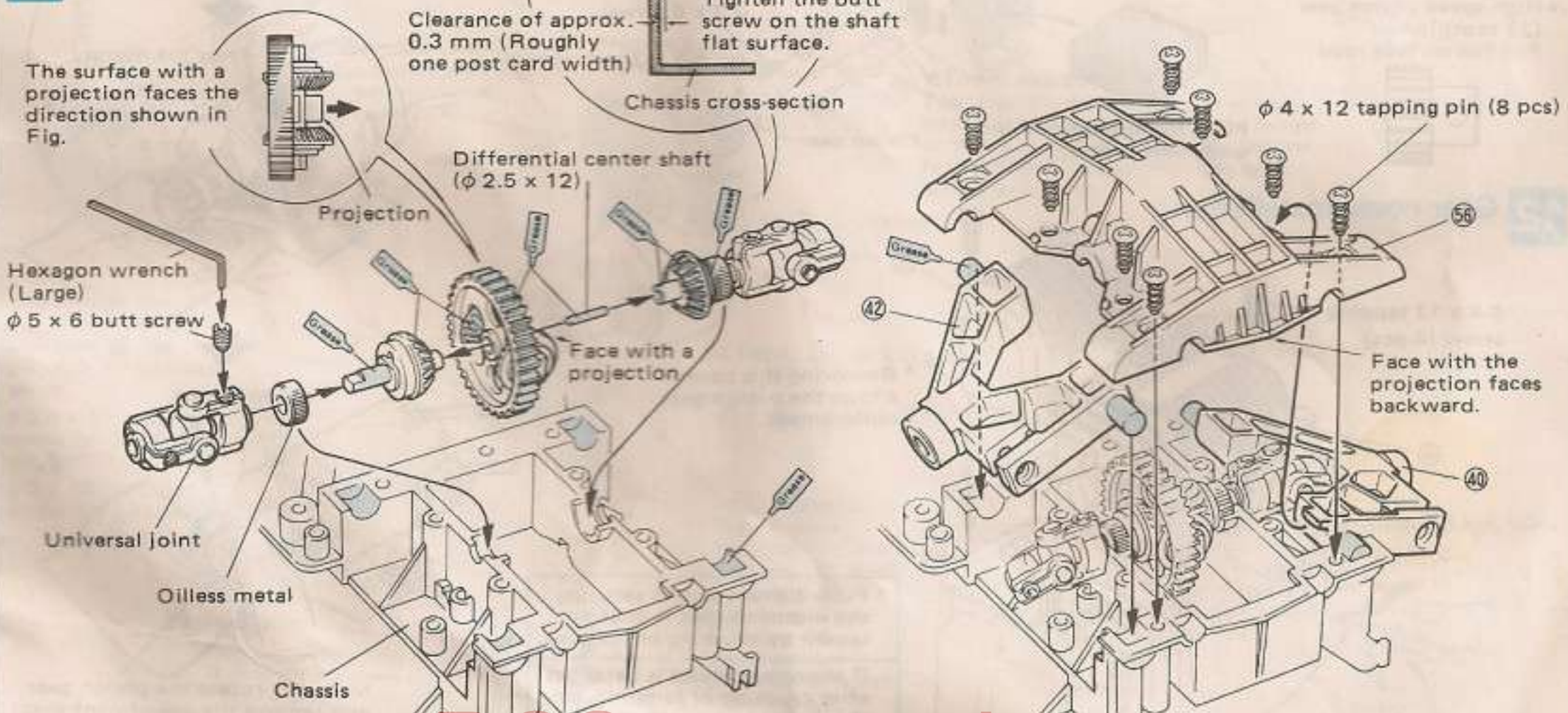



<Metallic part actual sizes used on P. 6>

φ 3 x 6 screw ..... 2 pcs

φ 3 x 10 tapping screw ..... 2 pcs

φ 4 x 12 tapping screw ..... 7 pcs

3 mm washer ..... 3 pcs

φ 3 x 3 butt screw ..... 1 pc

Idler shaft ..... 1 pc

3 mm spring washer ..... 2 pcs

4 mm spring washer ..... 3 pcs

## 10 Motor mount and idler gear installation

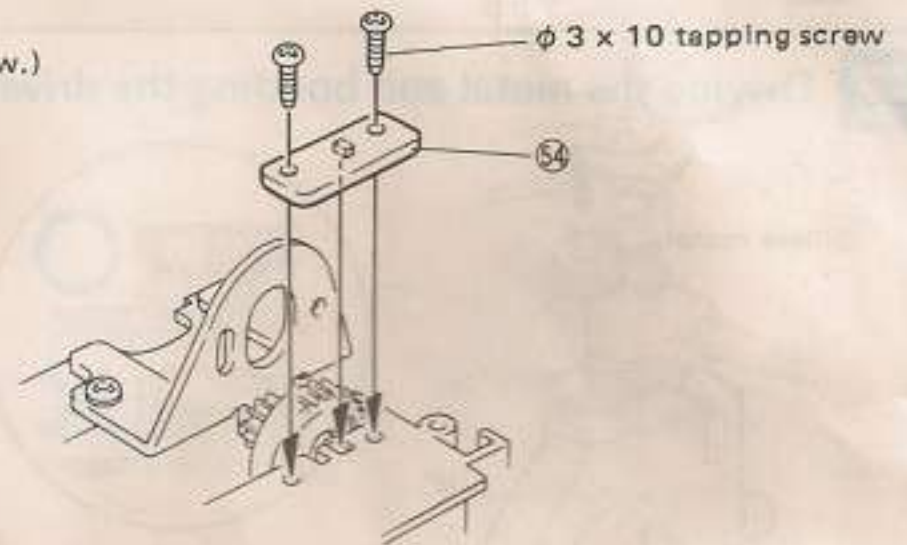
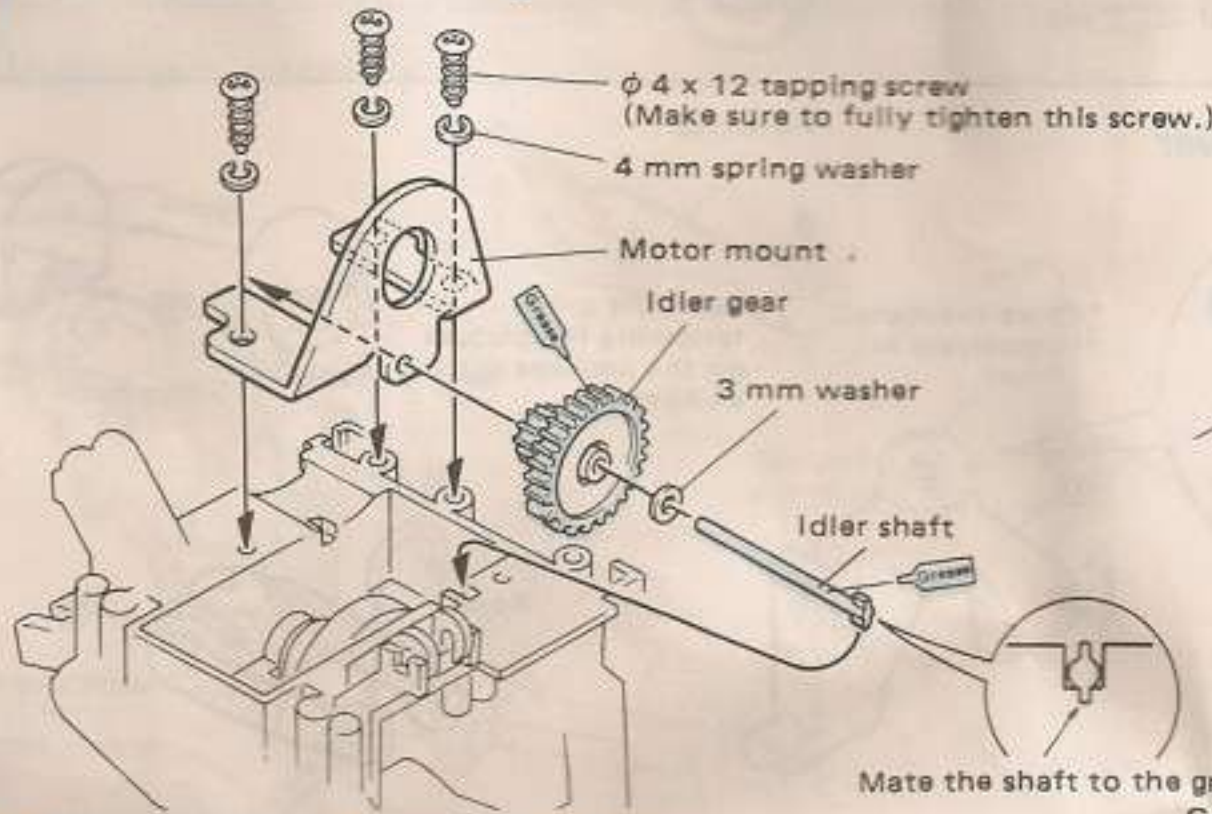

<Attaching the pinion gear>

Mate the shaft to the groove.

Gear engagement adjustment sheet included in the kit.

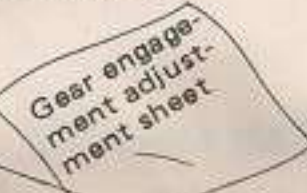

## 11 Pinion gear and motor installation

The motor becomes hot after operation. Be careful not to burn yourself.

<Pinion gear selection>

Select the proper pinion gear for driving conditions.

• High torque pinion gear (18 tooth): For rough surface road



• Regular pinion gear (20 tooth):

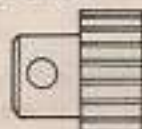

• High-speed pinion gear (22 tooth): For flat surface road

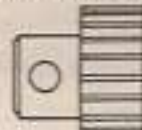

If an object such as a washer, staple, or pebble enters the hole in the motor, the motor will stop rotating and damage will result. To avoid such troubles, assemble the motor separately, away from other metal parts.

<Pinion gear position>

Align the centers.

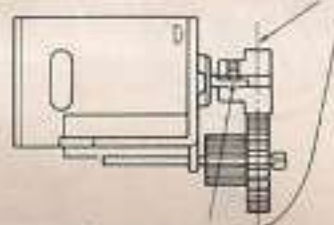

Tighten the screw so that both gear surfaces are levelled.

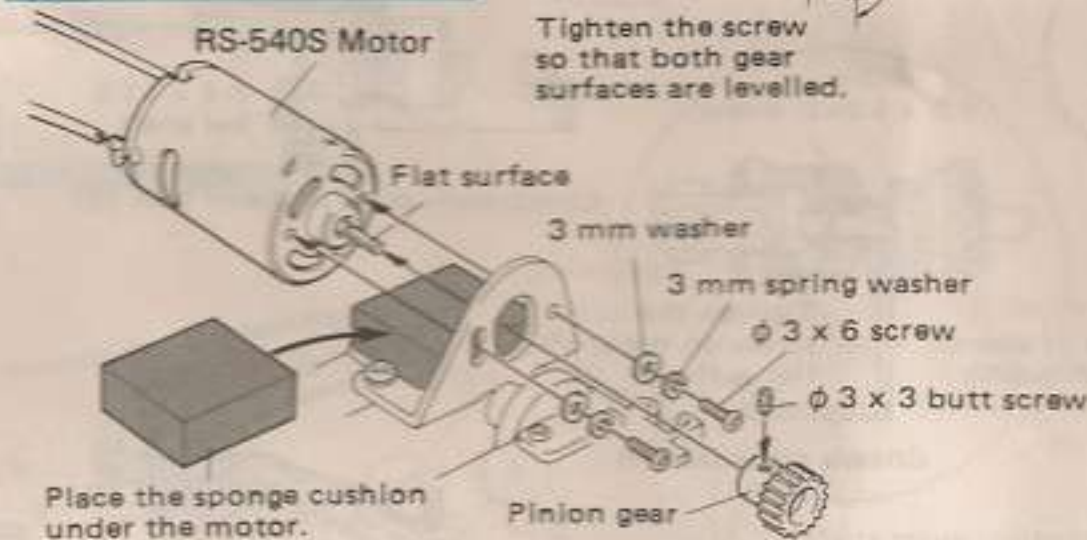

Loosen screws and pull the motor up as much as possible.

Loosen screws

Place the adjustment sheet between the pinion gear and idler gear.

Press the motor.

Tighten screws.

Manually rotate the pinion gear and remove the adjustment sheet (Be sure to apply grease.)

## 12 Gear cover installation

φ 4 x 12 tapping screw (4 pcs)

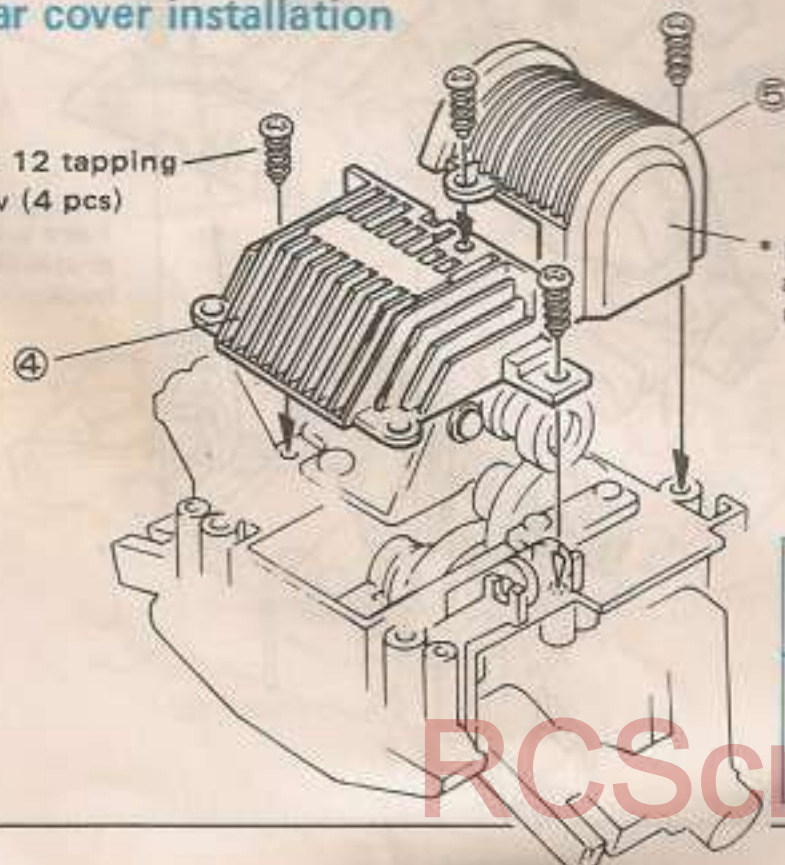

Removing this cover allows the pinion gear replacement.

Fully tighten screws securing the motor so that it does not loosen by crushing or jumping.

If abnormal sound is detected after crushing or jumping, stop the motor and check the gear engagement.



<Metallic part actual sizes used on P. 7>

- $\phi 3 \times 10$  screw ..... 4 pcs
- $\phi 3 \times 18$  screw ..... 2 pcs
- $\phi 2.6 \times 11$  tapping screw ..... 1 pc  
(For servos of FUTABA, JR, or KO)
- $\phi 3 \times 10$  tapping screw ..... 3 pcs
- 3 mm spring washer ..... 4 pcs
- $\phi 3 \times 14$  screw ..... 2 pcs
- $\phi 4 \times 12$  tapping screw ..... 2 pcs
- 3 mm washer ..... 8 pcs
- 3 mm nut ..... 6 pcs
- Rod adjuster (Long) ..... 1 pc  
58.8 mm (Aprox. 59 mm)
- Rod adjuster (Middle) ..... 1 pc  
42.5 mm

### 13 Rear guard installation

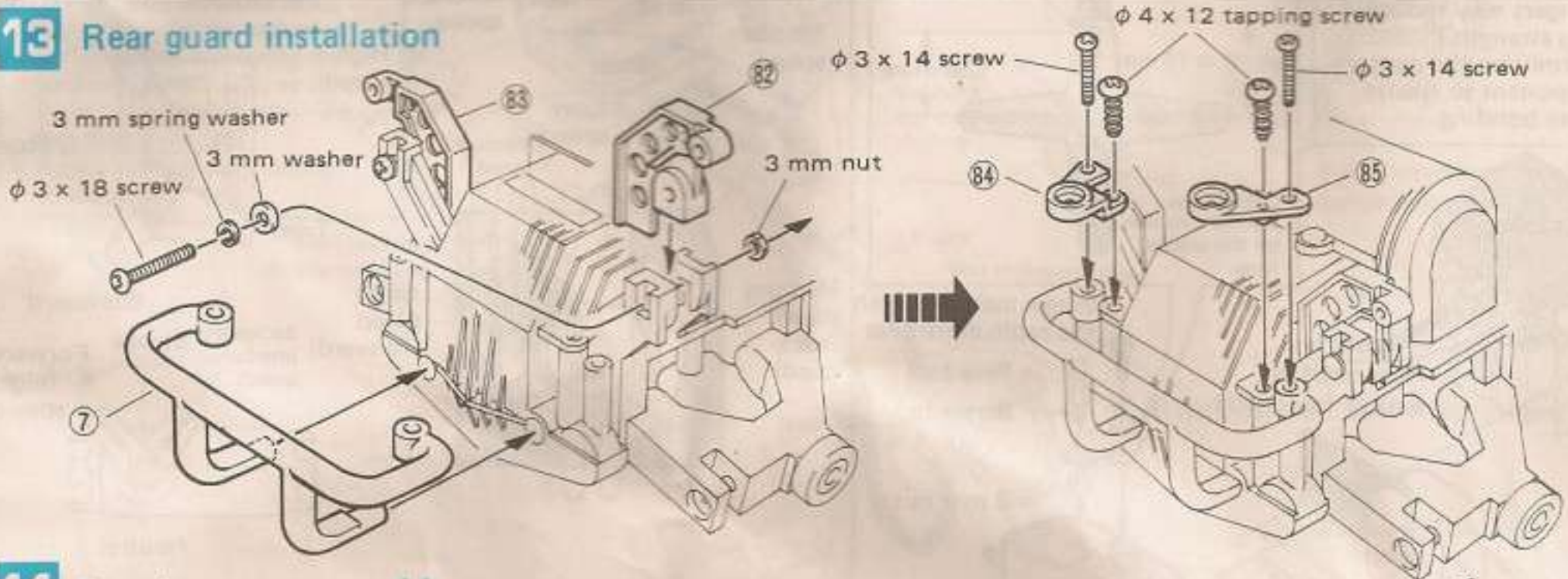

### 14 Steering servo assembly

<Tie rod assembly>

\* Ensure the use of correct components by comparing their actual sizes.

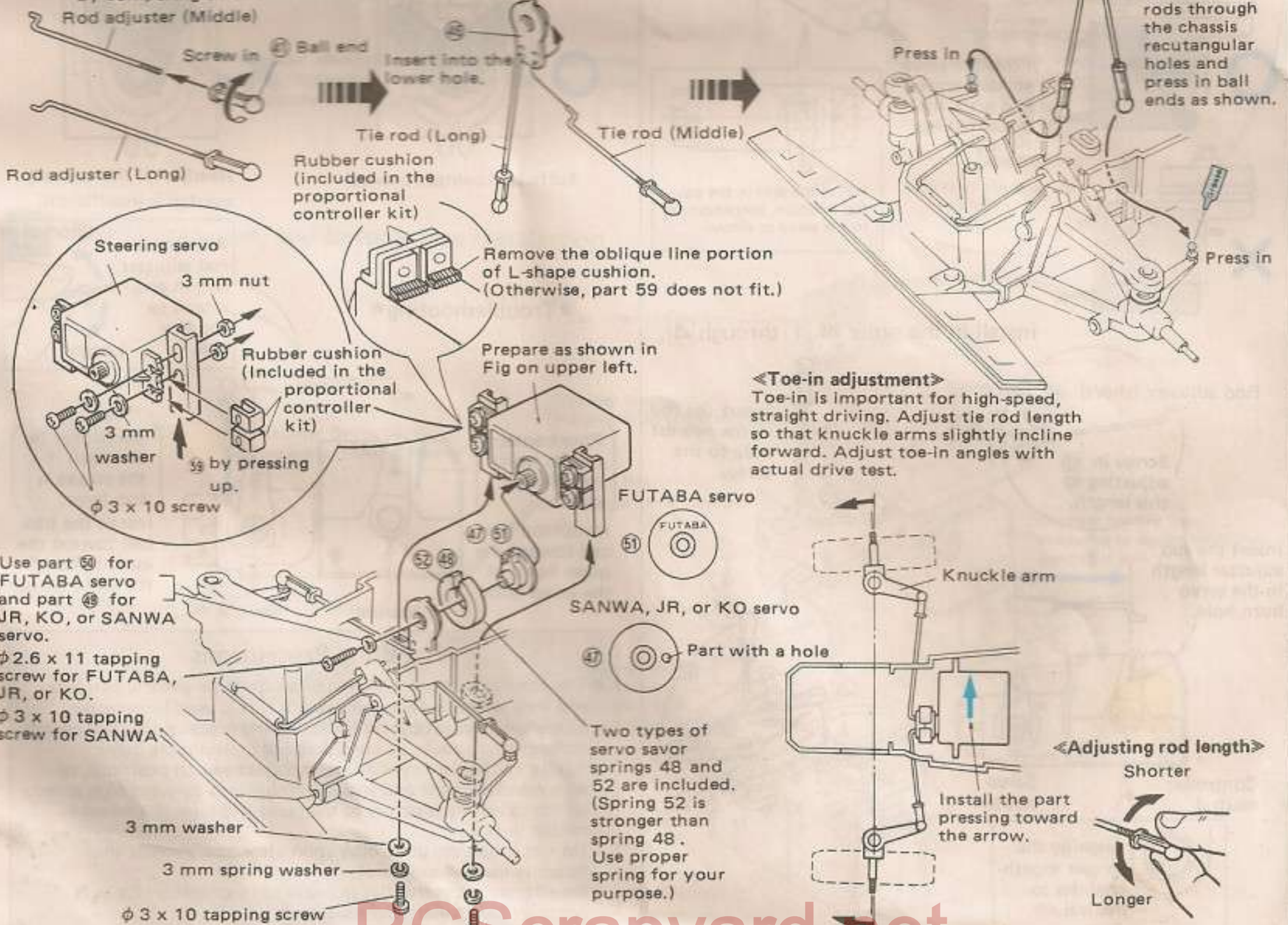



# 15 Speed controller assembly

(Connect the two servos with the receiver during this assembly. (See p.2 for details.)

◀Metal part actual sizes used on p.9▶

2 mm nut  
... 1 pc

Free ball  
... 1 pc

Rod adjuster (short)  
... 1 pc

- Clean tape mounting areas with paint thinner for plastics or other suitable solvent.
- Do not touch the adhesive surface after removing the backing paper. (Oil on your fingers may reduce bonding strength.)
- Press firmly on the controller component to ensure complete bonding.

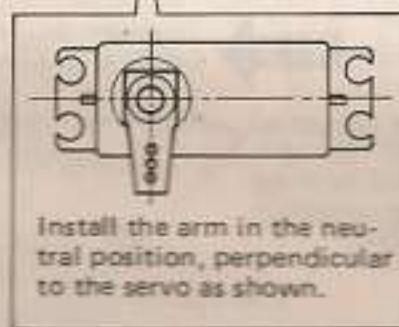
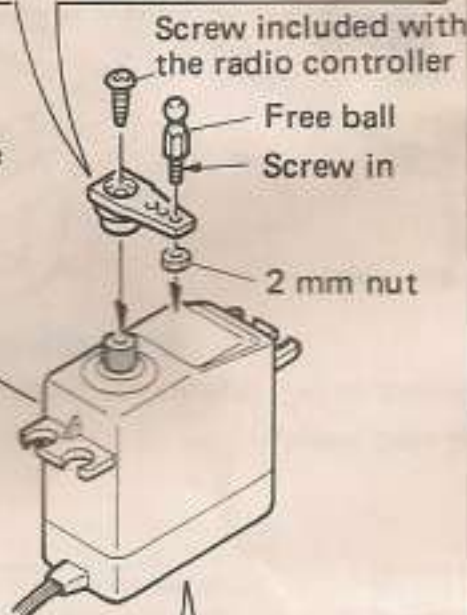
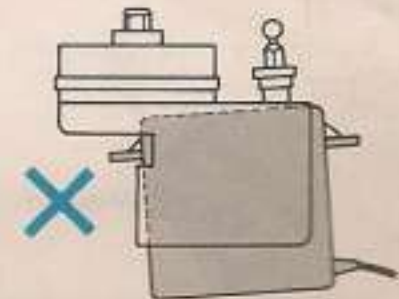
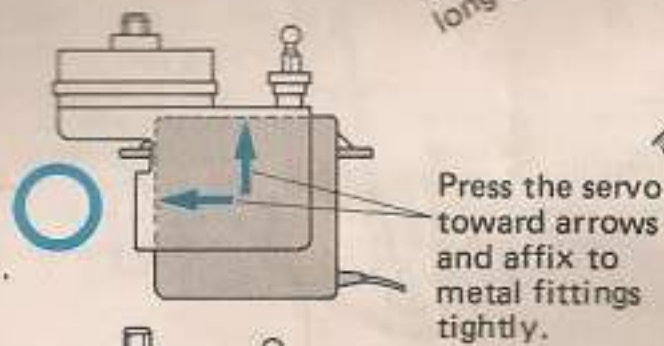
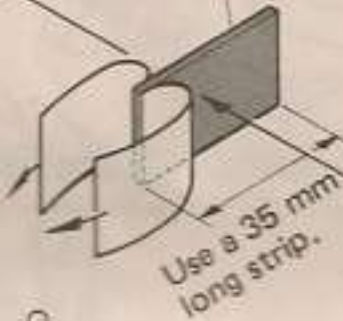
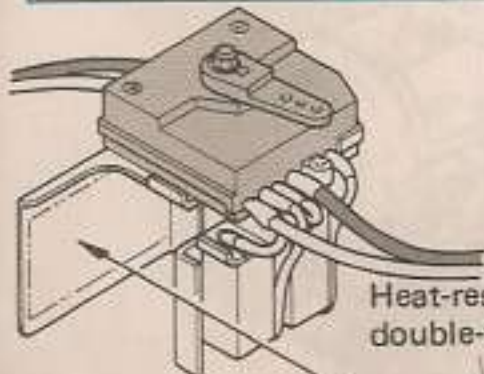
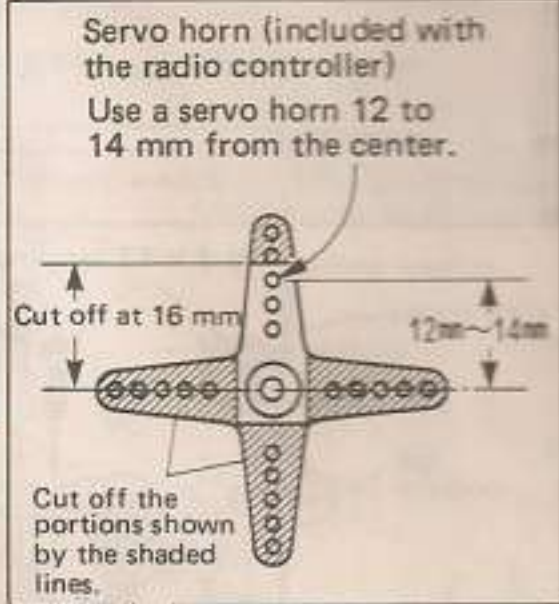

Install in the order of 1 through 4.

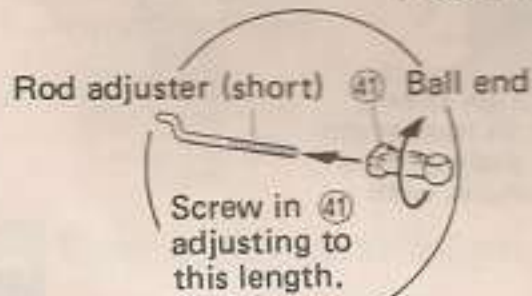

Insert the rod adjuster length in the servo horn hole.

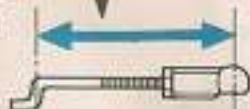

Controller neutral

Servo neutral

Aligning the arrows together shifts to neutral.

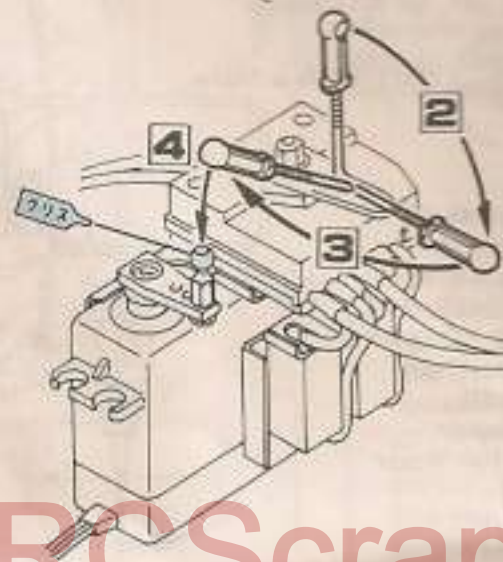

## ◀Stroke adjustment▶

- Servo horn stroke differs by servo type. Test to see if the switch arm moves all the way to its forward (high-speed) and reverse (high-speed) positions by moving the lever up and down.

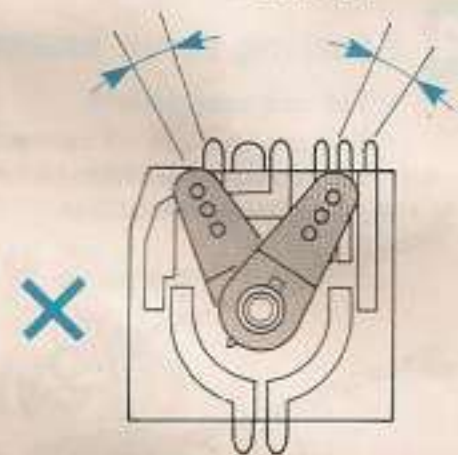
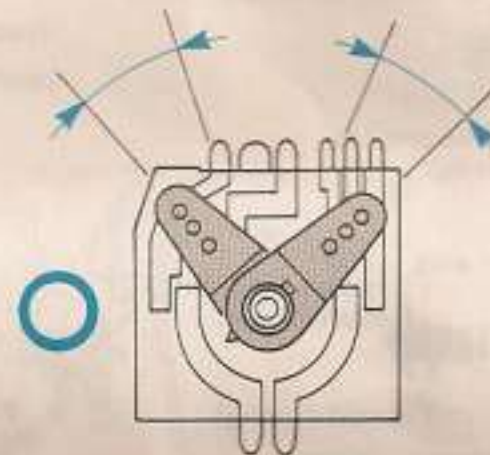
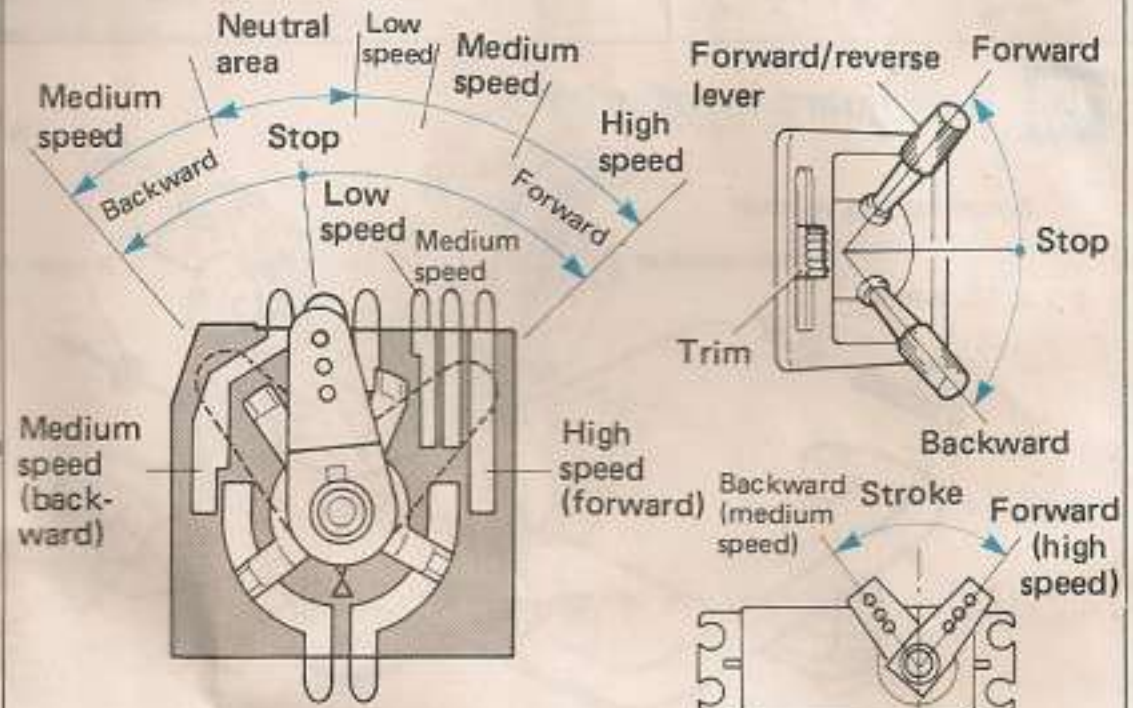

## ★Troubleshooting★

Poor contact results from insufficient stroke. Install the free ball toward the outer holes of the servo horn.

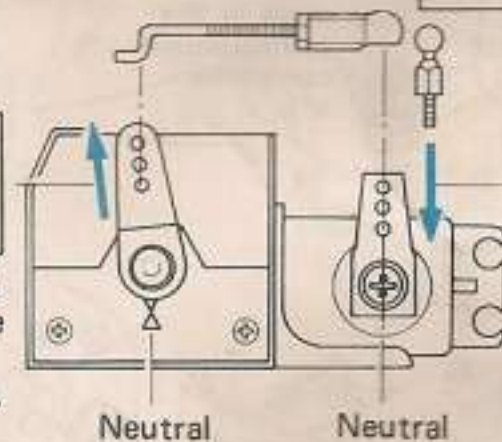

Servo may be damaged if the stroke is too large. Install the free ball toward the inner holes of the servo horn.



## Handling Precautions

- The controller must frequently switch large electric currents, and may become damaged quickly if it is used incorrectly. Therefore, please observe the following precautions. The switch components should be considered as consumable items.
- Faulty controller installation, incorrect switch positions, or wire misplacement prevents switching into forward high speed, which cause the resistors to overheat and burn the printed circuit board.
- Do not touch the controller soon after operation as the resistors may be quite hot.
- Do not use the controller in a closed mechanical box as it contains heat generating resistors.



## 16 Speed control servo installation

- Clean bonding areas with thinner for use on plastic.
- Do not touch the adhesive surface after removing the backing paper. (Oil or dirt from your fingers may reduce bonding strength)
- Apply sufficient pressure to secure the servo.

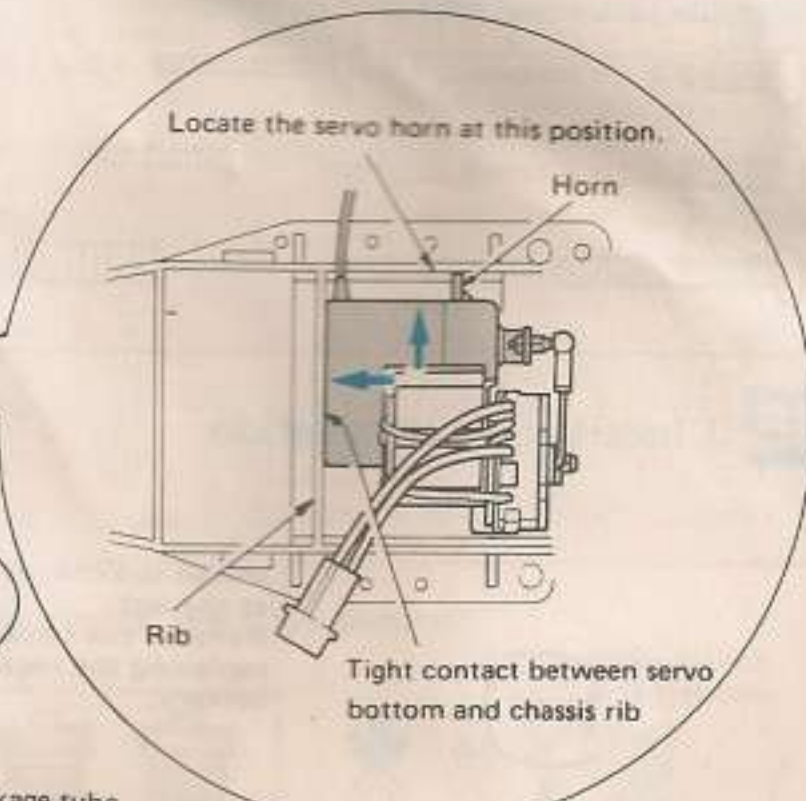
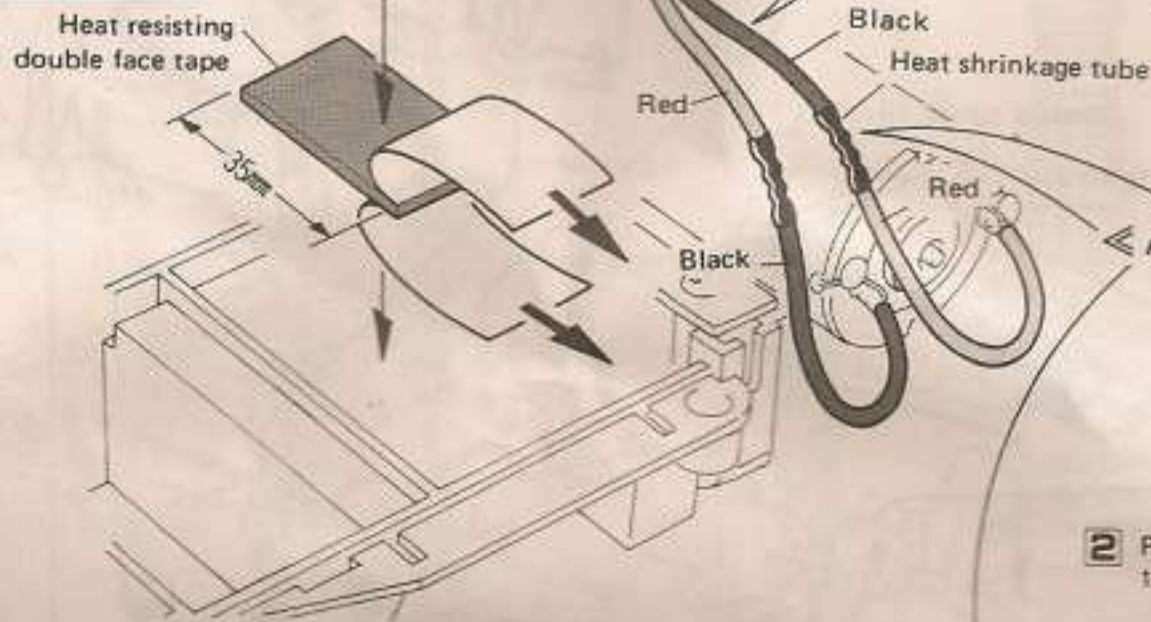

- If the car reverses when the radio controller lever is forwarded, the motor and controller connections are incorrect.

### Attaching heat shrinkage tube

- 1 Cut the tube into half.
- 2 Pass the wire through tube.
- 3 Twist the cords.
- 4 Cover the twisted cord area with the tube. Soldering recommended.
- 5 Heat the tube using a dryer.

## 17 Switch, receiver, and battery box installation

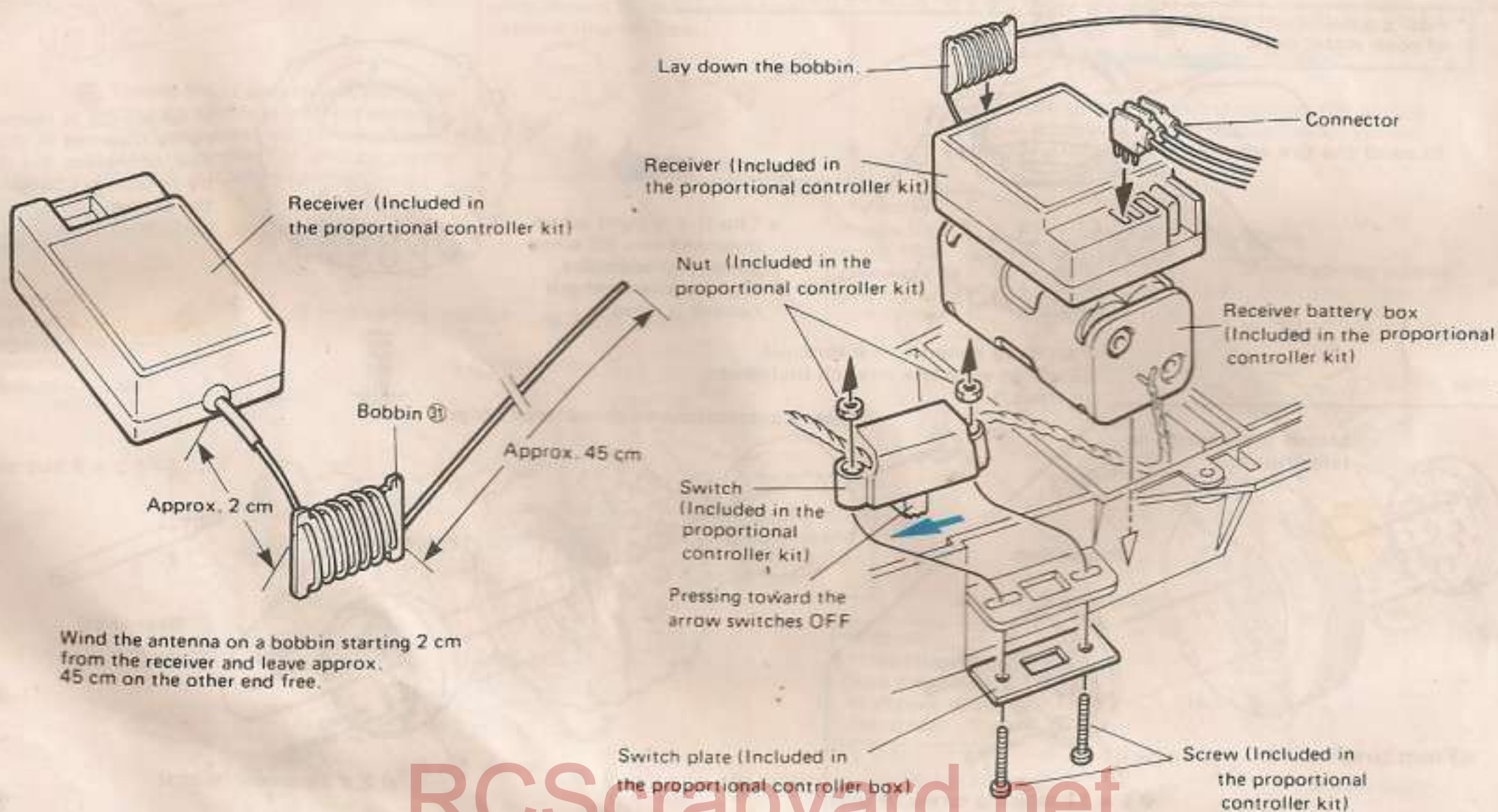

Wind the antenna on a bobbin starting 2 cm from the receiver and leave approx. 45 cm on the other end free.



<Metallic part actual sizes used on P. 10>

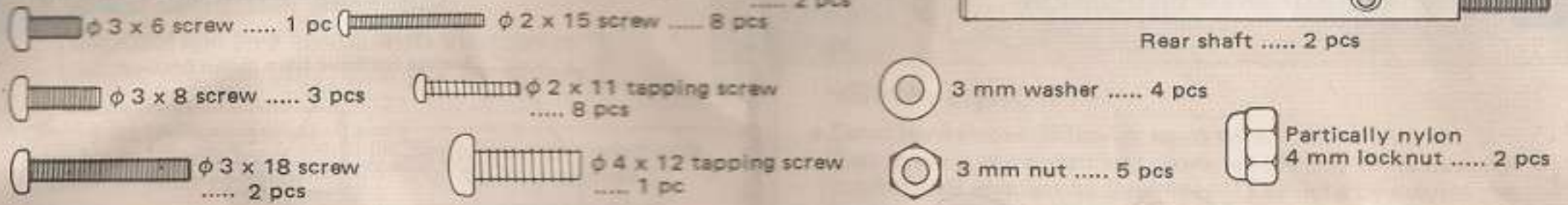

## 18 Chassis cover installation

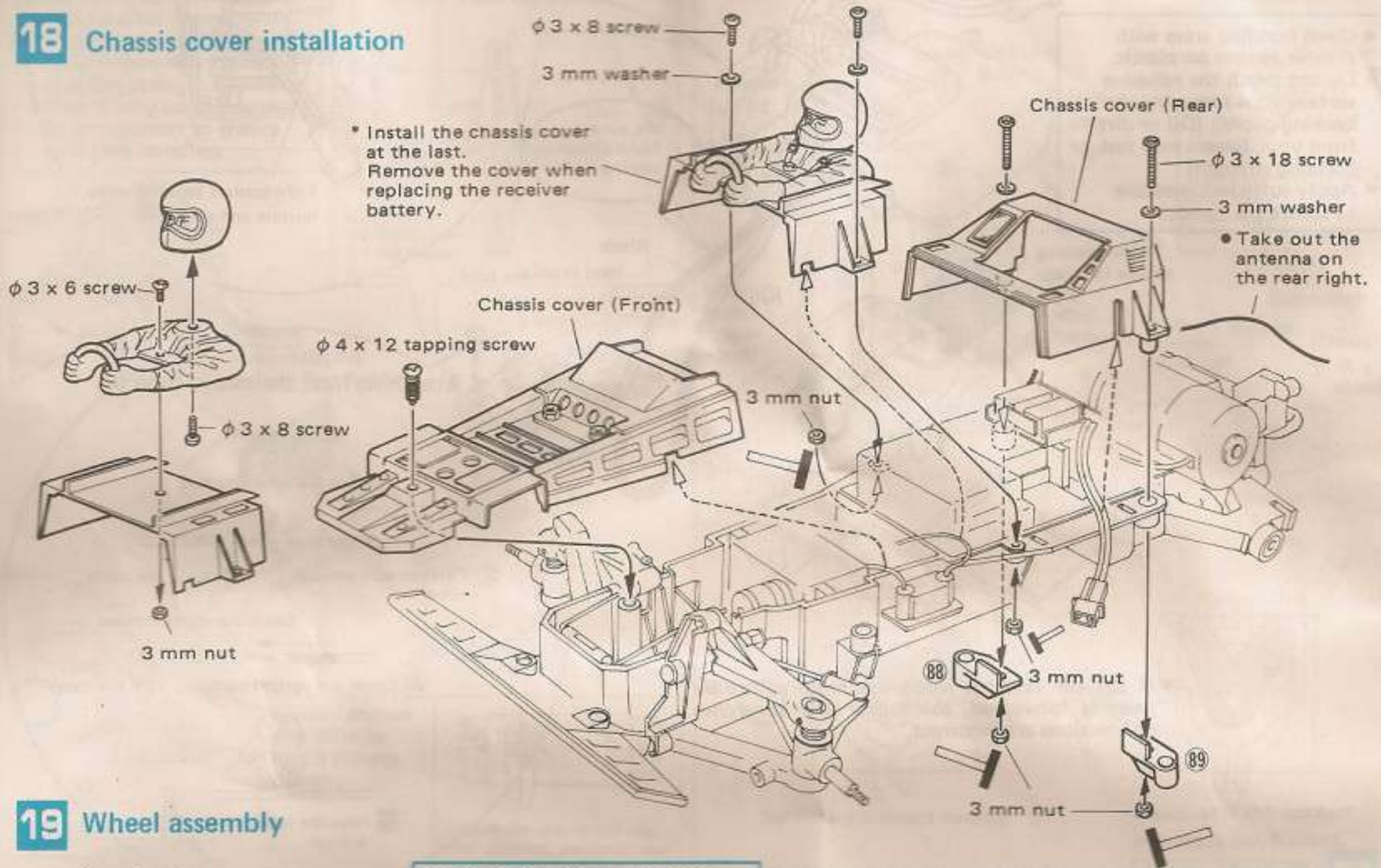

## 19 Wheel assembly

<Rear tires>

• Apply a sufficient amount of soap water here.

Do not apply soap water here. (Wheel will be slippery if applied.)

Expand the tire edge.

• The tire is tight when inserting rim 23 since abrasion resistance, high tensile strength rubber is used.

If wheel 23 is temporarily inserted in the tire, complete the job by rotating it toward the arrow.

Partically nylon 4 mm locknut (Tighten with the wrench included in the kit.)

Match projections to large holes.

Match projections to these large holes.

Projection

Projection

Rear shaft.

<Front tires>

$\phi 2 \times 11$  tapping screw (8 pcs)

$\phi 2 \times 15$  screw (8 pcs)

RCScrapyard.net



◀Metallic part actual sizes used on P. 11▶

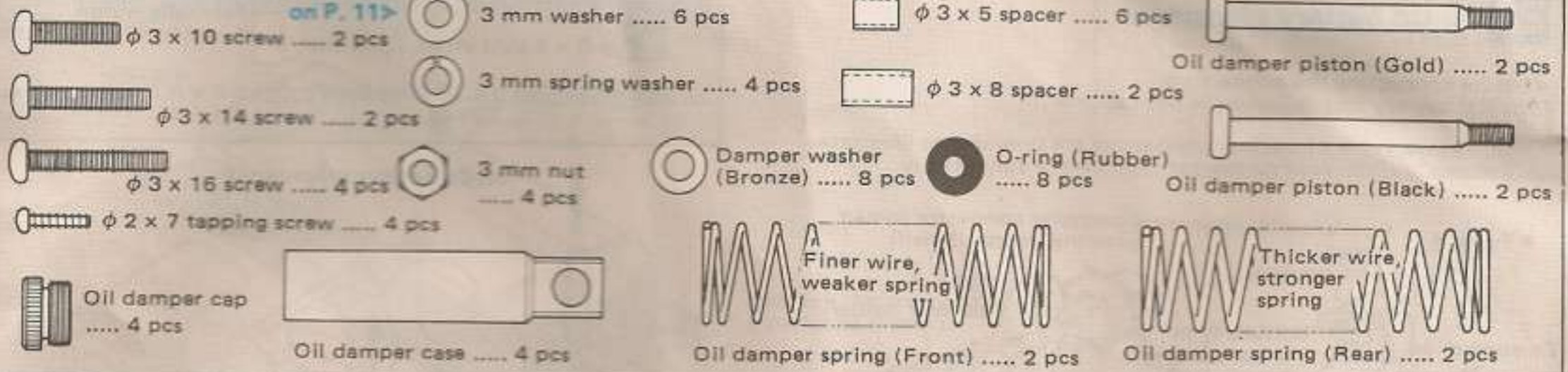

## 20 Oil damper assembly

● Be careful on colors for front and rear pistons. (Each two pistons)

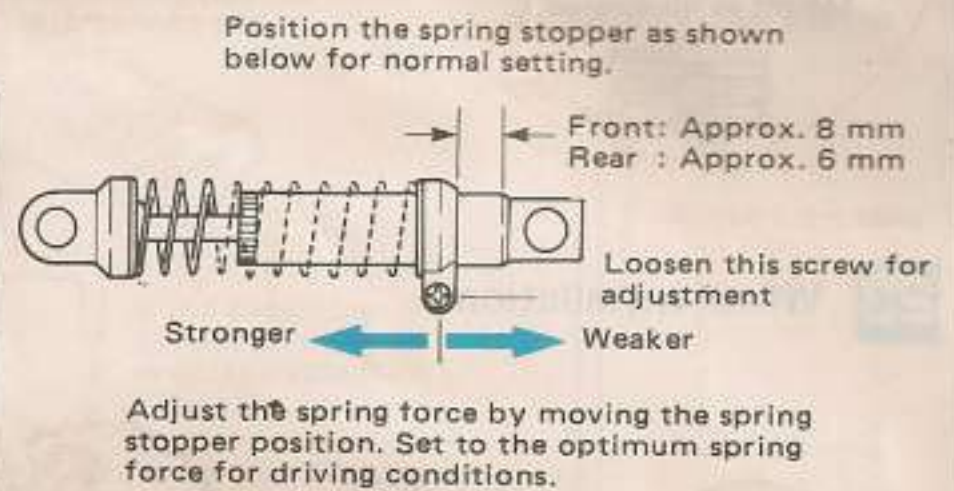
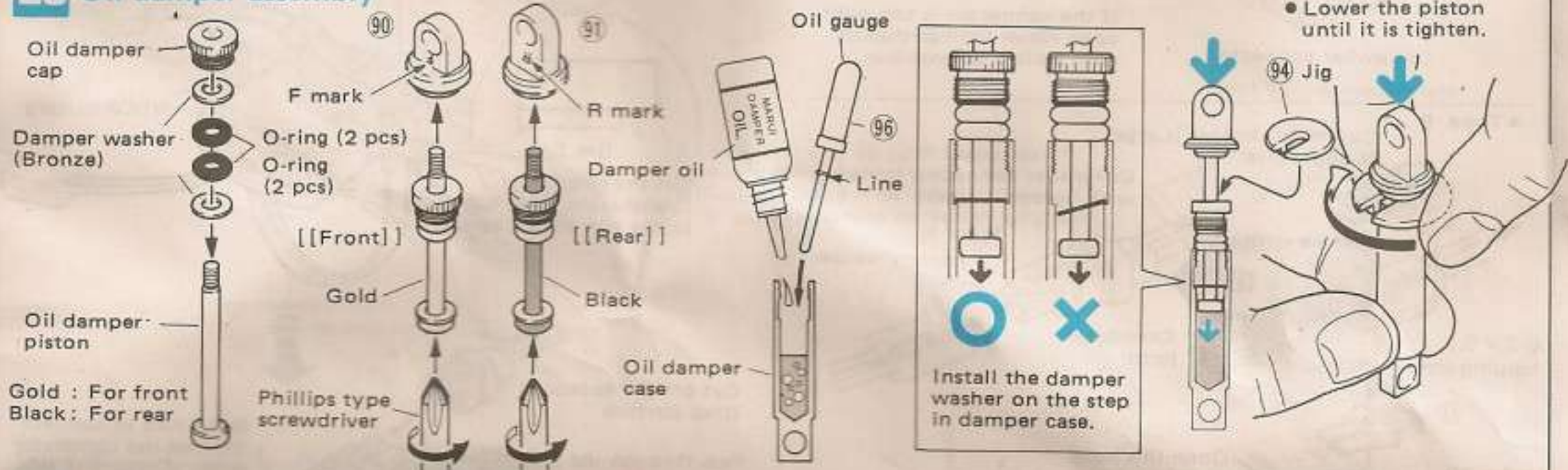

## 21 Oil damper installation

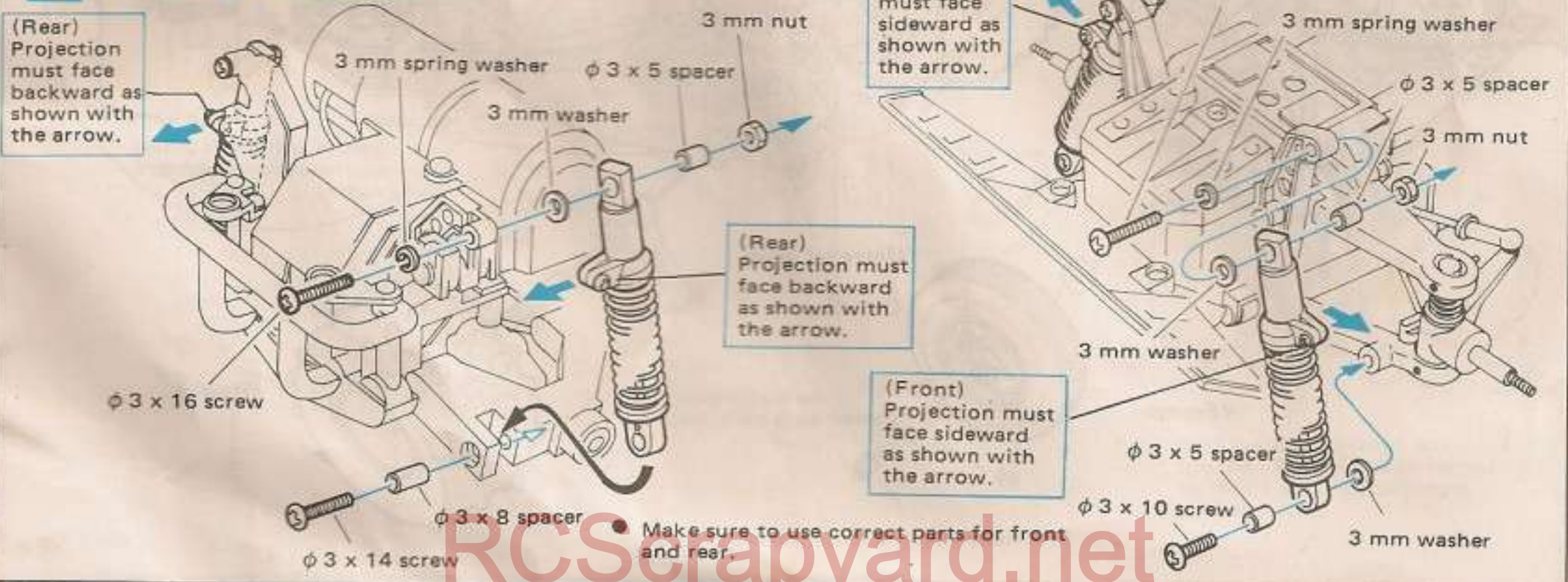



## 22 Ni-Cd battery placement

«Before connecting the connector»  
(For 6 V battery, the following is not required.)

\* Two types of battery connectors are provided as illustrated below. Confirm your connector type before connection.

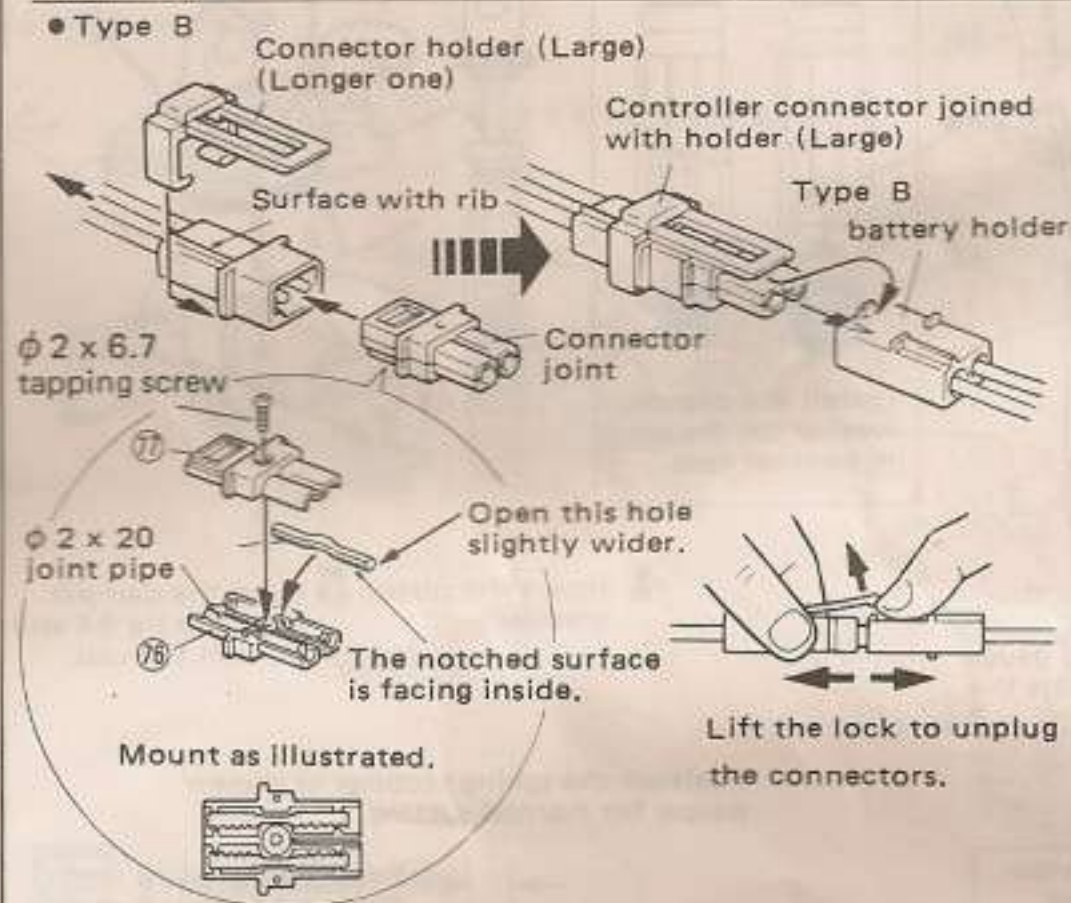
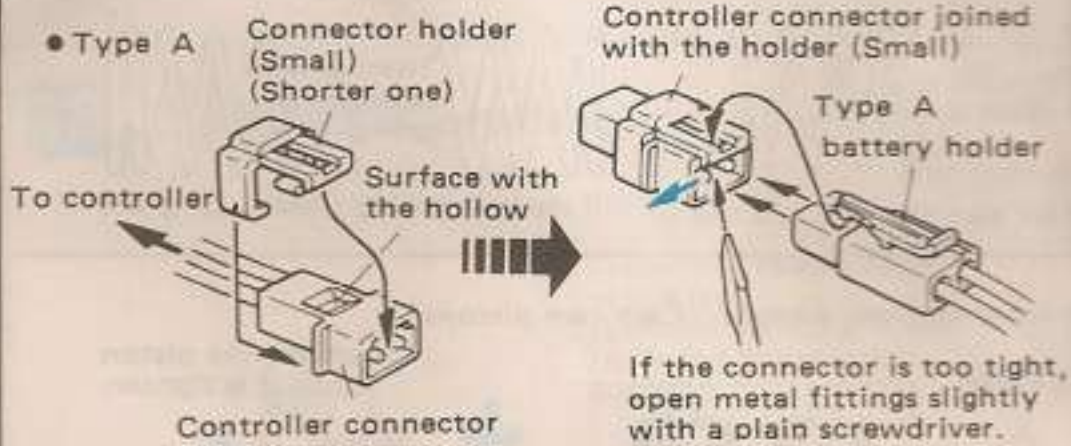

«Metallic part actual sizes used on P. 12»

φ 5 x 6 butt screw ..... 2 pcs

Partially nylon 4 mm locknut ..... 2 pcs

φ 2 x 20 joint pipe ..... 2 pcs

φ 2 x 6.7 tapping screw ..... 1 pc

«Ni-Cd battery placement»

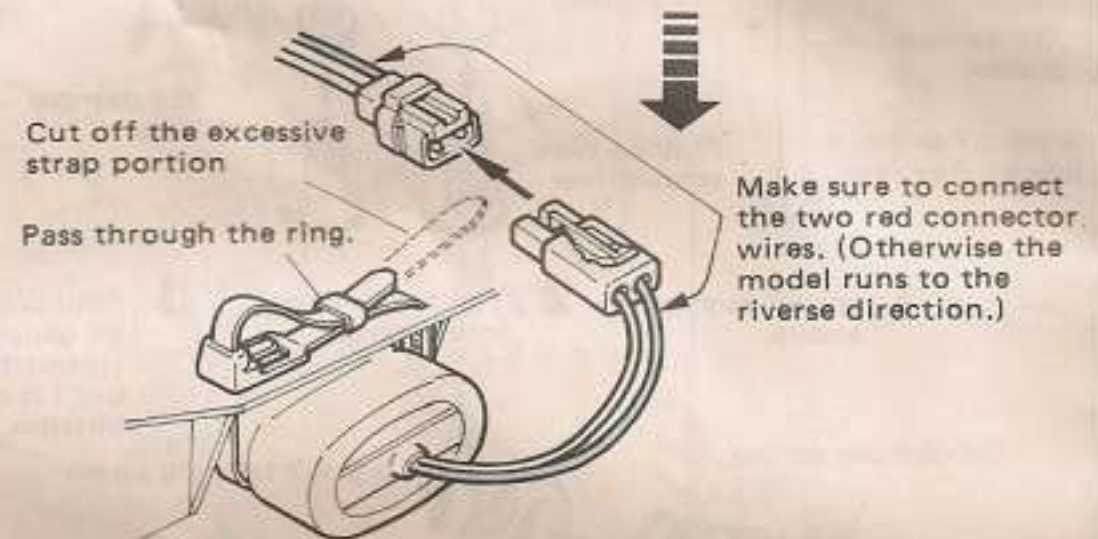
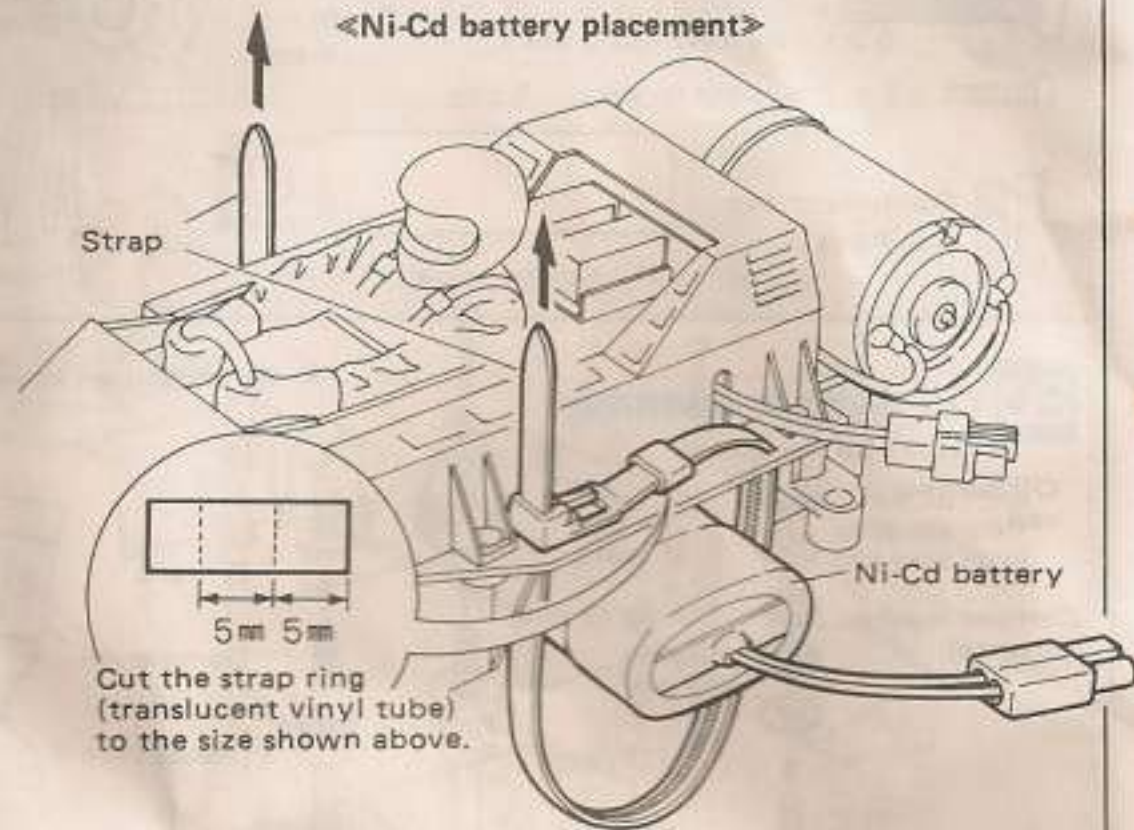

\* Set the switch arm at the neutral position when plugging the connectors. (see switch position on P. 8)  
Plugging connectors without switching OFF may result in damaged controller battery or motor.

## 23 Wheel installation

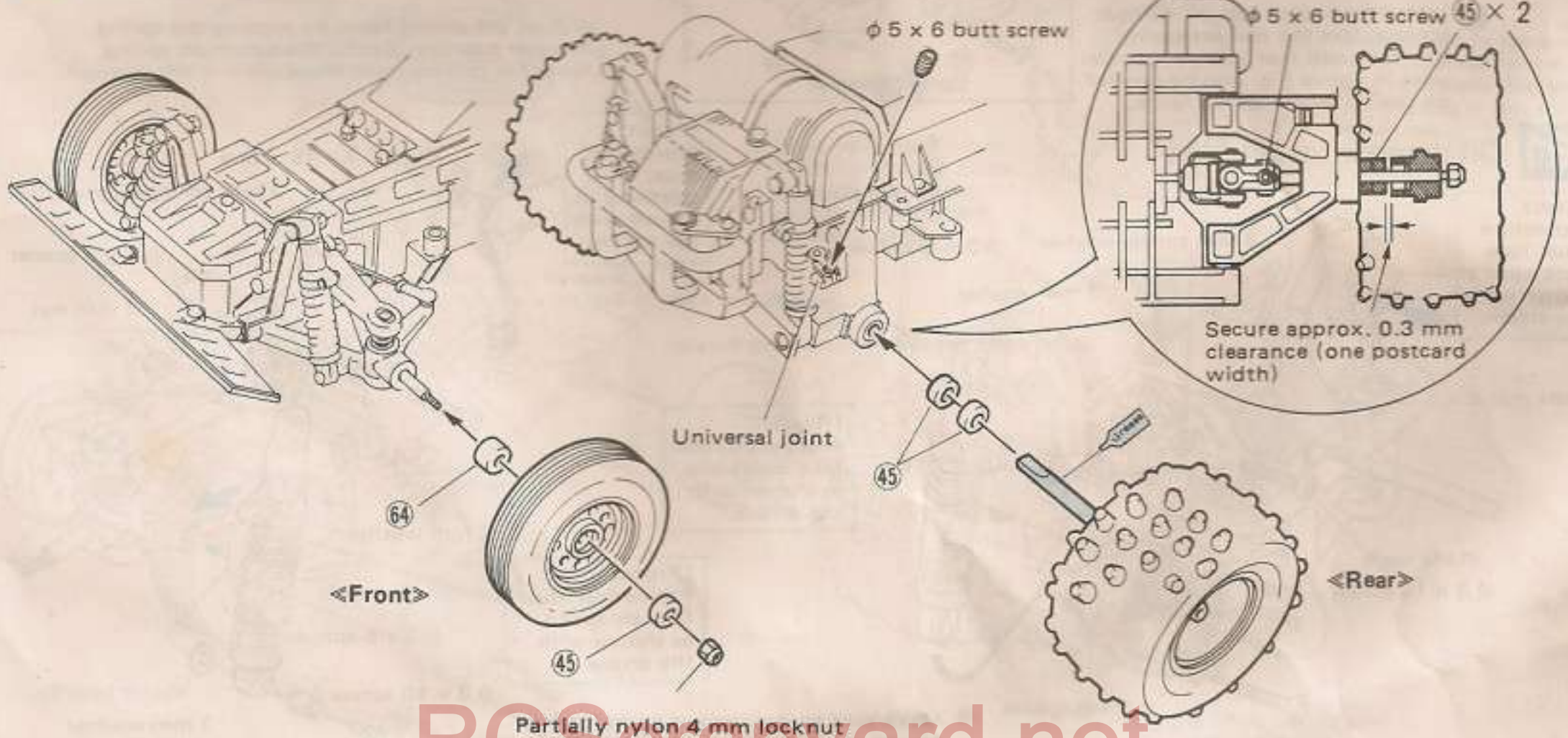



Partially nylon 4 mm locknut

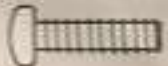

## 24 Wing and player's number plate installation

<Metallic part actual sizes used on P. 13>

  $\phi 3 \times 10$  tapping screw  
..... 10 pcs

 3 mm washer ..... 2 pcs

<Wing>

Drill a  $\phi 3.2$  hole with a gimlet or drill bit.

Remove the grey area with a cutter or scissors.

<Wing cross-section view>

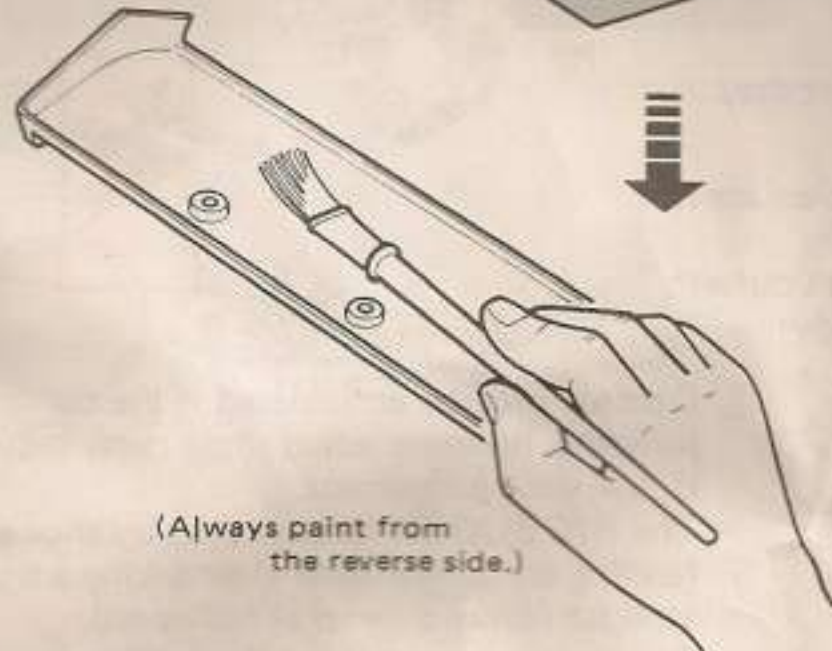

(Always paint from the reverse side.)

- Clean dirt and oil with soapy water before painting.
- Coat the body interior with paint for polycarbonate or laquer for metal.

Paint for polycarbonate



## 25 Pipe frame (roll bar) installation

<Mounting the antenna pipe>

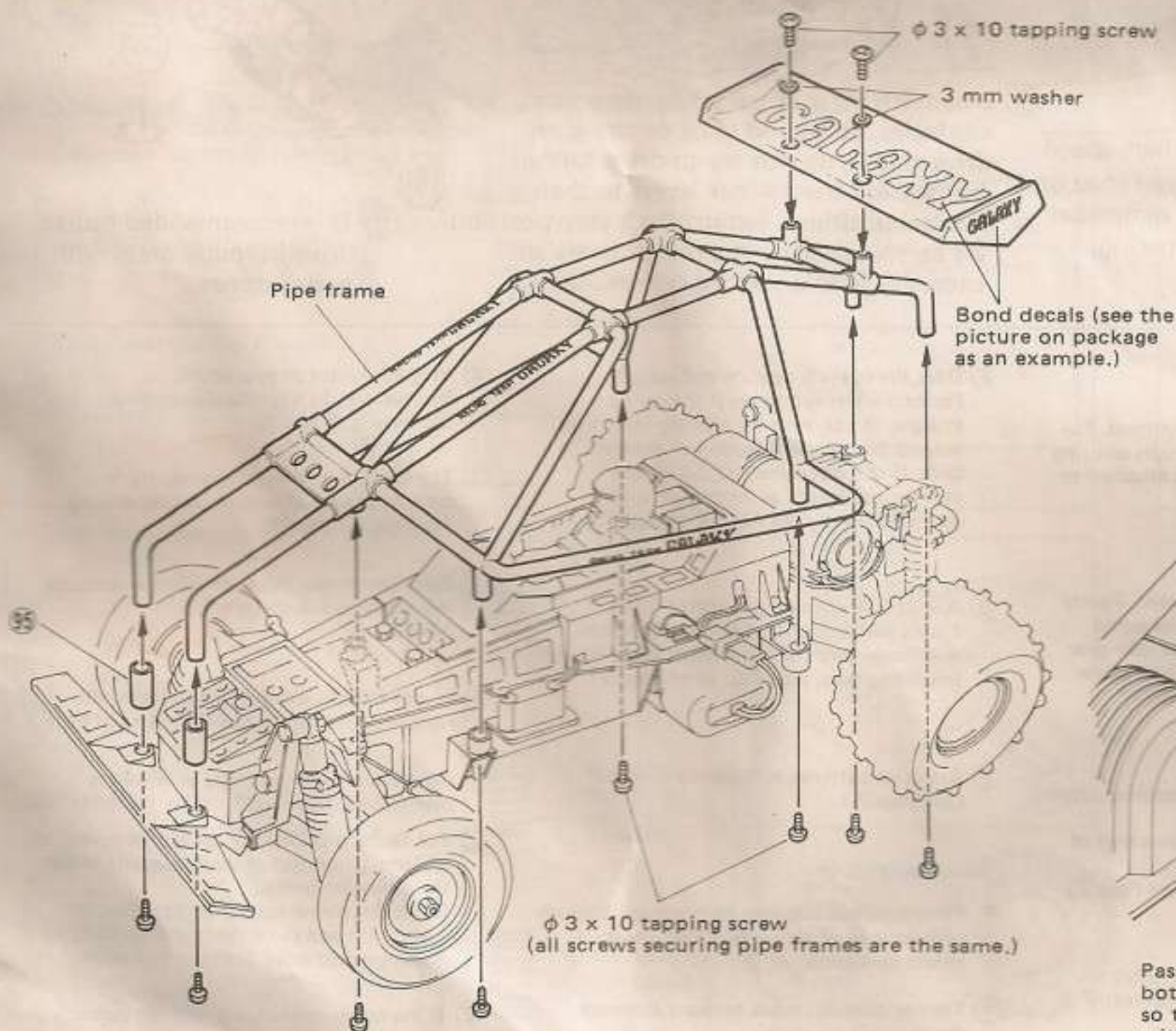

$\phi 3 \times 10$  tapping screw

3 mm washer

Pipe frame

Bond decals (see the picture on package as an example.)

$\phi 3 \times 10$  tapping screw  
(all screws securing pipe frames are the same.)

Tie this portion so that wire does not fall.

About 5 cm long

Antenna pipe

Press antenna pipe into this chassis hole after passing the wire through the pipe.

Pass the wire through the bottom. The wire is stretched so that it will not be tangled with the tire.



## Handling precaution

The R/C BUGGY is designed as a high-speed off-road racing car. Be careful while handling and operating this model.

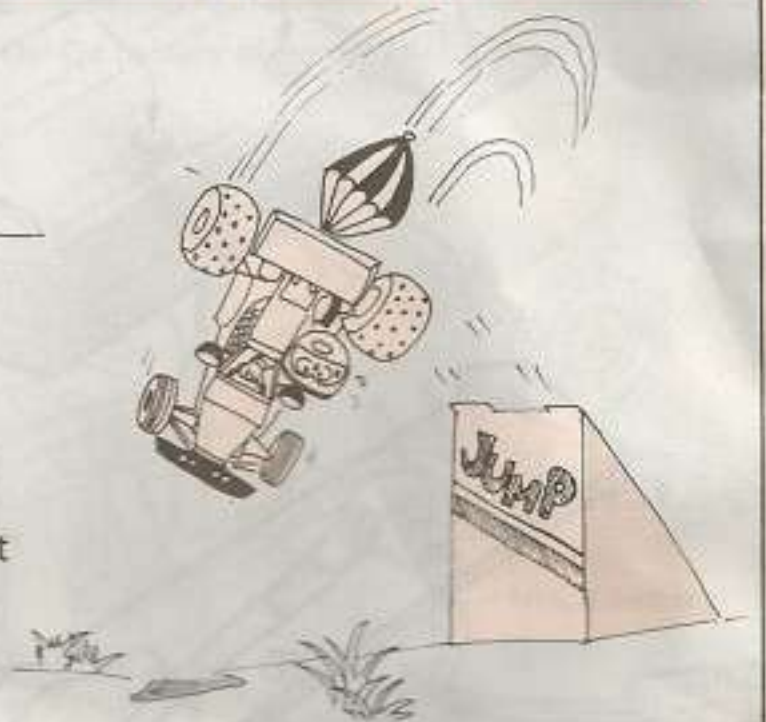

- ① Do not operate at a crowded location or where children are present.

- ③ Avoid sloppy areas as water may damage the model.  
④ The controller and motor are hot after operation. Be careful not to burn yourself. (Do not touch carelessly)

- ⑦ Damage may be anticipated if the car jumping, however when some races require it, use your judgement. The R/C BUGGY ideal weight balance enable landing on its rear tires after taking a level straight forward jump at full-speed. Avoid unbalanced front tire landings because these heighten the possibility of damage.

- ⑤ Avoid grassy areas as long grass may become wound on drive shafts.



- ② The car may overturn if a high-speed turn is performed on a paved road or grassy lawn. Make sure to remember the basic principle for cornering, slow in and fast out.

- ⑥ When driving is impaired by deep sand, obstacles, or wound grass or string on drive shafts, do not try to drive further, but set the transmitter levers to their neutral positions (controller's stop position). Be careful because the motor bears an excessive load under these conditions.



- ⑧ It is recommended not to drive in rough areas with many stones.

### Checks before driving

- ① Check all screws and nuts for tightness. Pay special attention to screws and nuts securing the suspension, and butt screws attached to the universal joint.
- ② Check gears for correct engagement. Faulty pinion gear engagement due to loosened motor securing screws may cause idler gear damage. Check the pinion gear butt screw for correct tightness. (See Page 6.)
- ③ Are proportional controller batteries supplying sufficient power? Receiver battery life is shorter than that of the transmitter, and early battery replacement is recommended. (See Page 2.)
- ④ Does the controller operate correctly? Make sure that the controller is correctly adjusted. (See Page 8.)

- ⑤ Does the steering operate correctly? Perform a test run to see if the car runs straight. If not, turn the steering lever trim toward the reverse direction of the car's drift. If still not corrected, adjust the steering rod length as instructed in the assembly sheet. (See Fig. 14 of page 7.)

- ⑥ Are all wire connections tight? Faulty insulating vinyl or soldered areas may cause short circuit. Repair using vinyl insulating tape. (See Fig. 18 of Page 9.)

- ⑦ Are drive batteries sufficiently charged? (See Page 2.)

### Troubleshooting

- Following troubles may be corrected through performance of above described checks before operation.

- ① The car does not move forward although the motor is operating. See Page 5, 6, 8, and 12.

- ② Irregular motor or gear sound. Rear wheels do not rotate smoothly. See Page 5, 6, and 12.

- ③ The car does not respond properly to control or runs at random during driving. See Page 2, 7, and 8.

- ④ Speed controller does not operate correctly including no full-speed drive. See Page 8.

- ⑤ Faulty straight driving, or turning to the right and left differs. See Fig. 14 to of Page 7.

- ⑥ Controller, drive batteries, or wires are over-heated. See Page 8.

- ⑦ For faulty proportional controller operation including improper servo movement, check the following points: Sufficient power supply by batteries, correct (+) and (-) battery connections, an discontinuous servo or connector wires.

- ⑧ If the faulty operation is still not correct after the above, contact your dealer for repair.



# PART LIST

**ABS Parts ① x 1** Parts ①, ②, ③, ⑥, and ⑨ are not used.

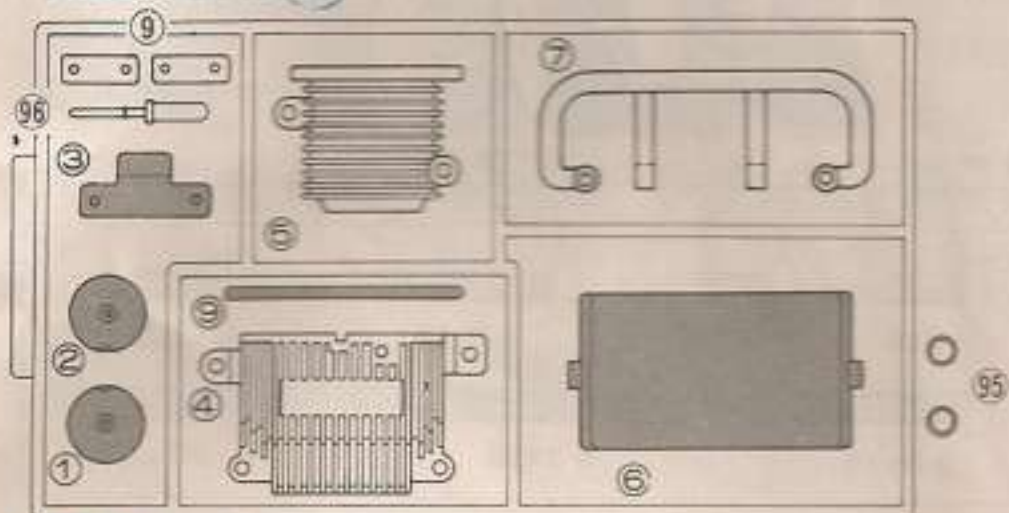

**ABS Parts ② x 1**

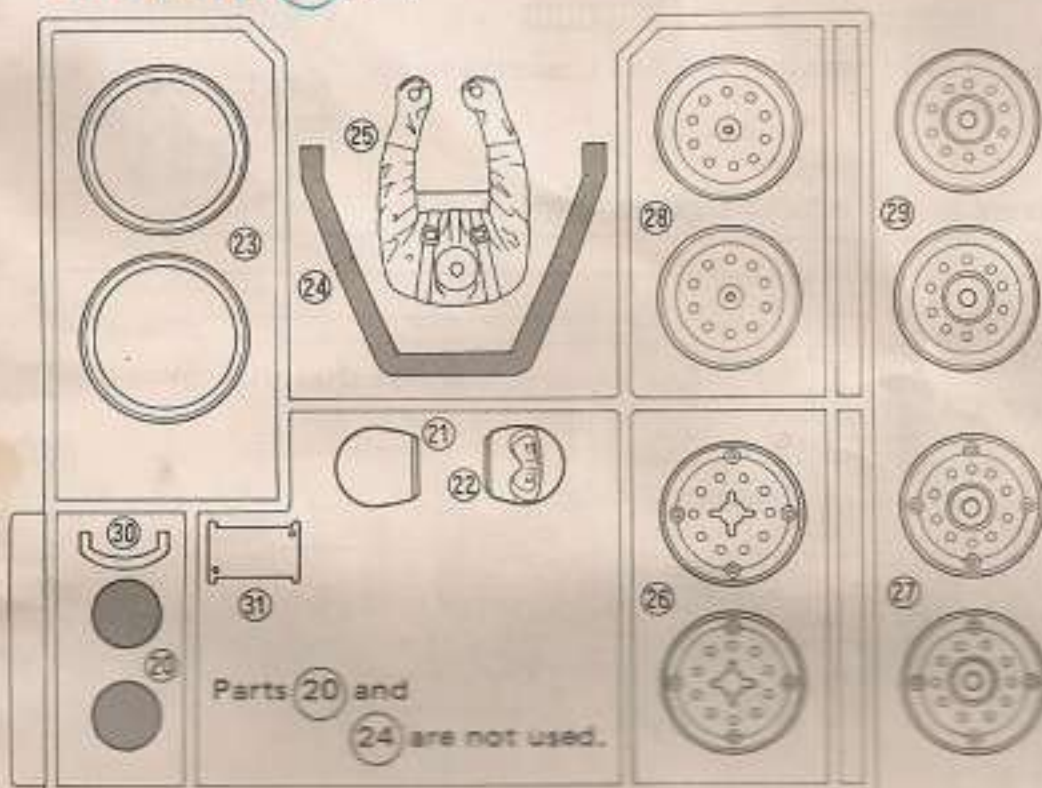

Parts ②① and ②④ are not used.

Reinforced nylon parts **Ⓐ** x 1

Parts ④③, ④⑤, ④⑤, ④⑧, and ④② are not used.

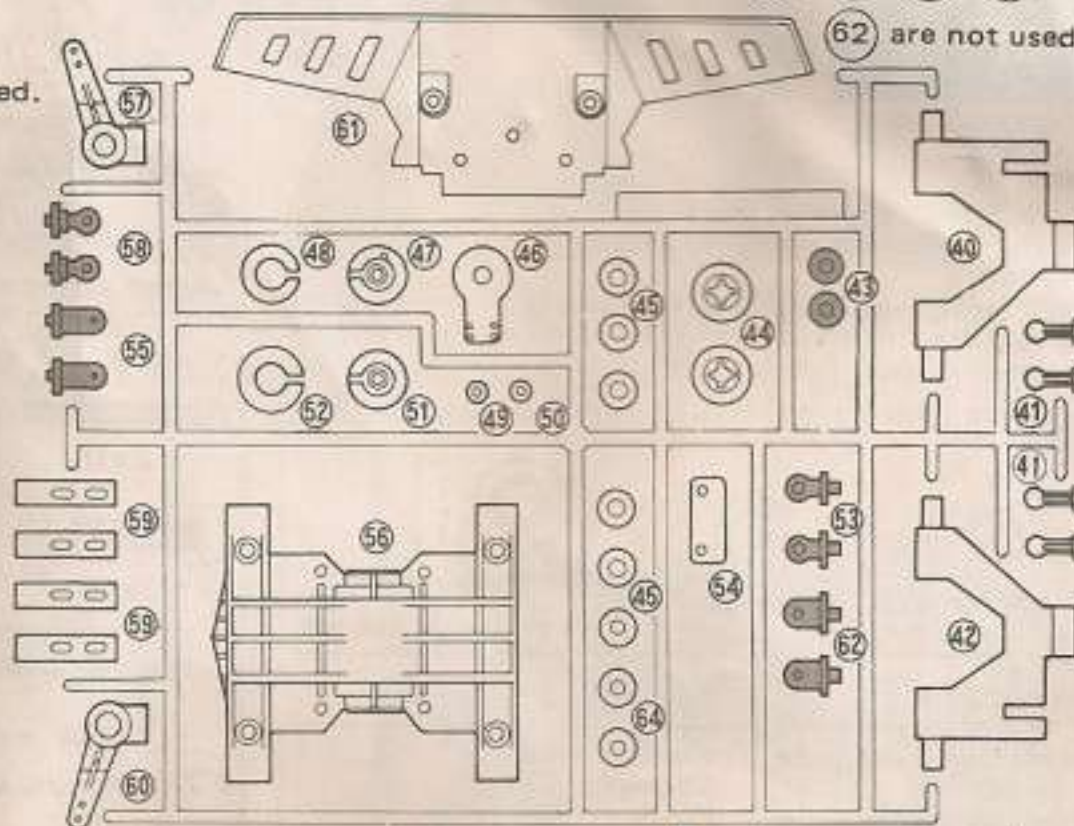

Reinforced nylon parts **Ⓒ** x 1

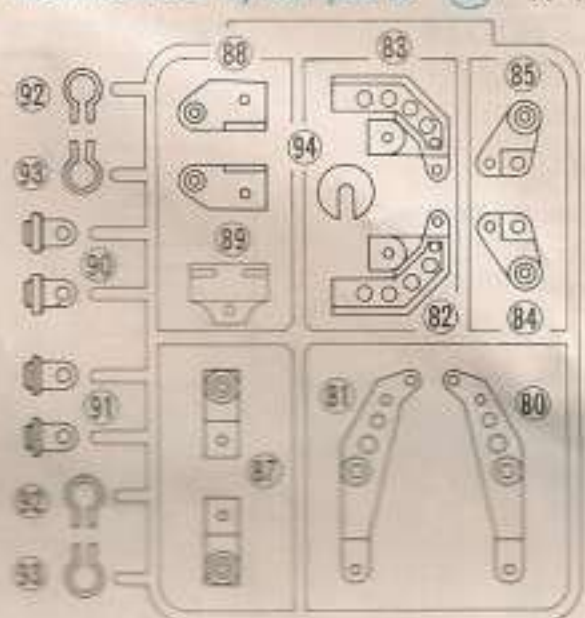

Front suspension set

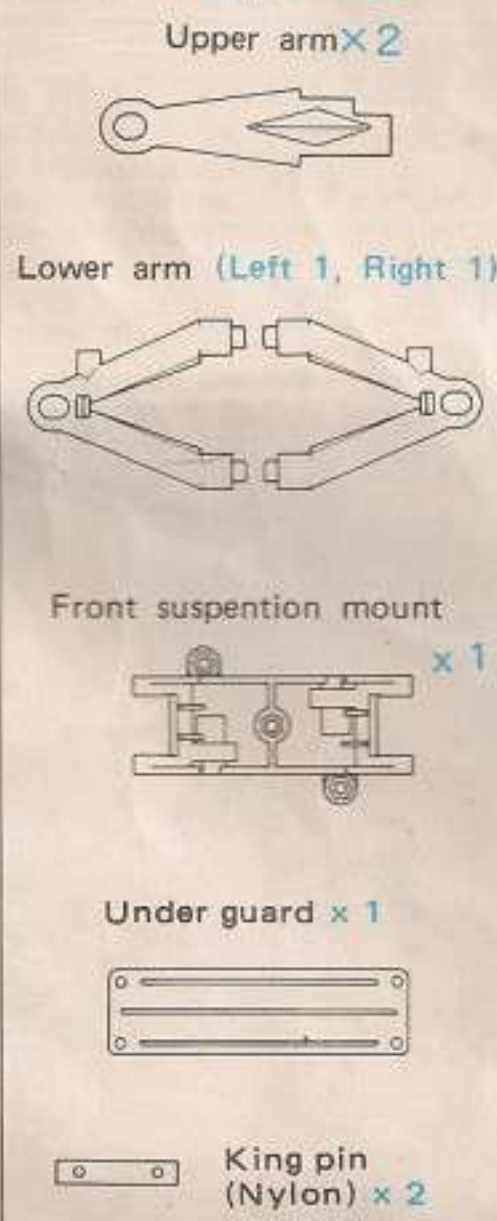

Damper set

Oil damper sprint (Front) x 2

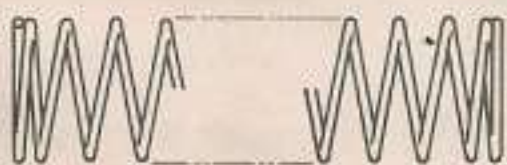

Oil damper spring (Rear) x 2

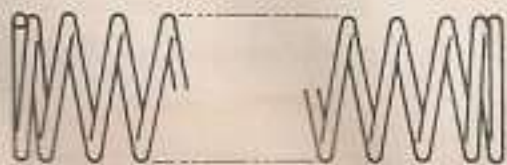

Oil damper cap x 4



Damper oil x 1



Damper case x 4

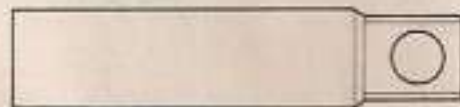

When a spare part set is required, the following parts are included:

- ★ Oil damper piston (Front x 2, Rear x 2)
- ★ Damper washer x 8
- ★ O-ring x 8

Gear set

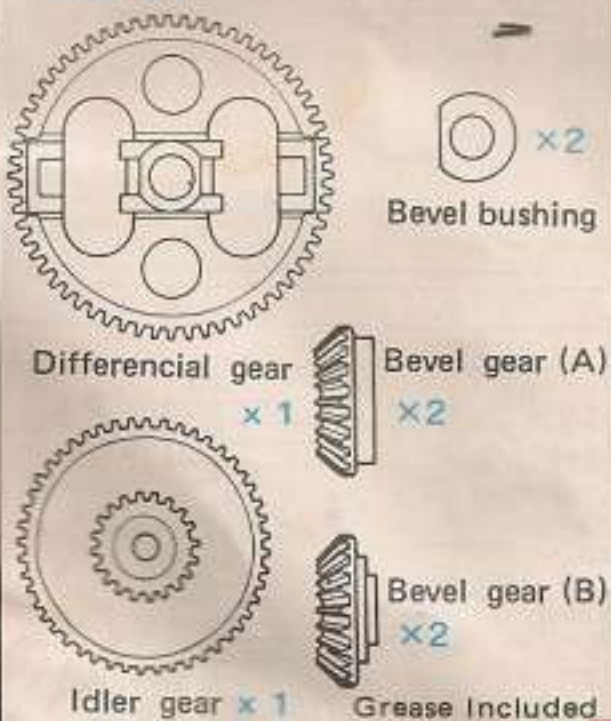

Pinion gear set



Controller

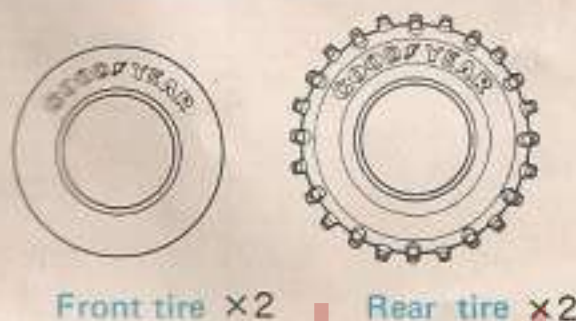
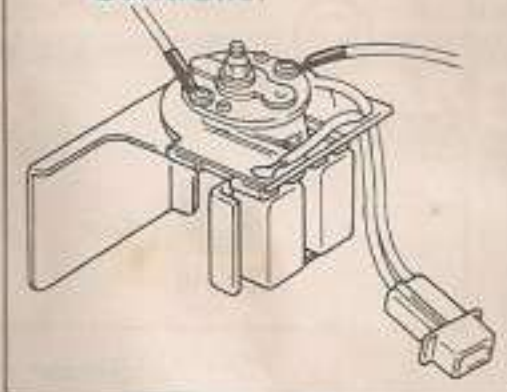

Motor mount x 1

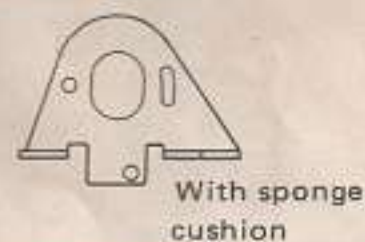

Universal joint x 2

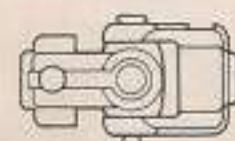

MABUCHI RS-540 Motor x 1

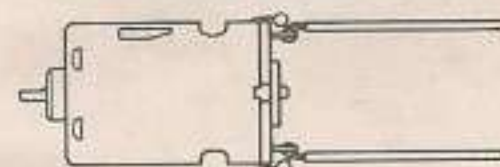



# PART LIST

Some types of screws and nuts are included excessively for spare part use.  
 ("φ3" in figures represents "3 mm diameter")

## Nut set



## C Set

Heat shrinkage tube (Large) x 1	Rubber tube x 1
Heat shrinkage tube (Small) x 1	Sponge x 1
Translucent tube x 1	Pliers x 1
	Bond x 1
	Grease x 1

## Other Parts

Chassis x 1	Wing x 1
Chassis cover (Front, Middle, Rear) ..... 1 each	Decal sheet x 1
Pipe frame x 1	Strap x 2
Heat resisting, double face tape (Black) x 1	
Gear engagement adjustment sheet x 1	

\* Spare parts may be purchased separately.

## Washer set



## Screw set

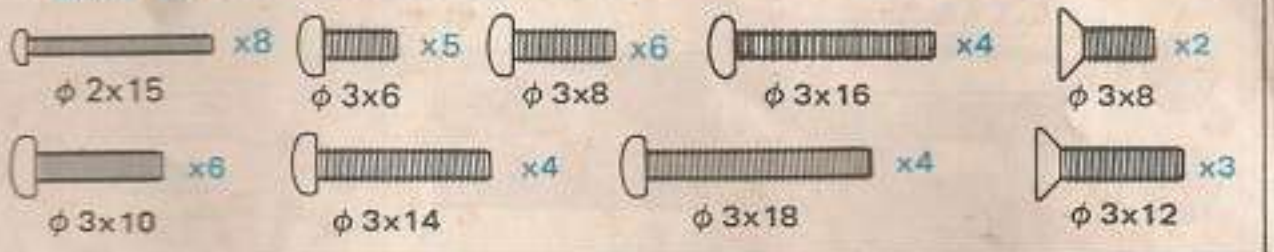

## Tapping screw set

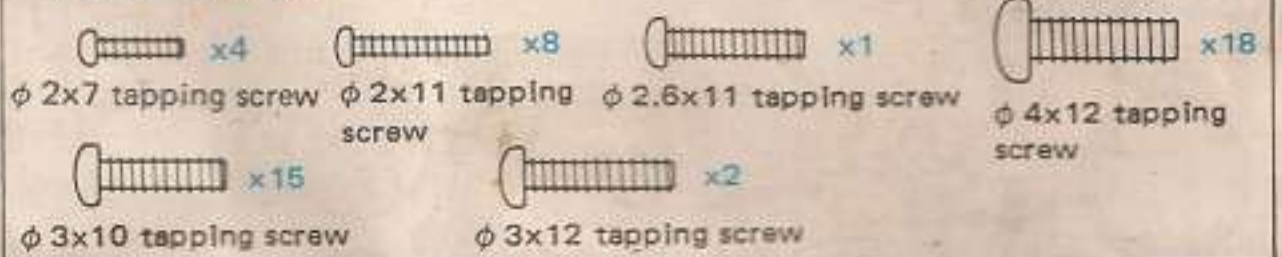

## Shaft set

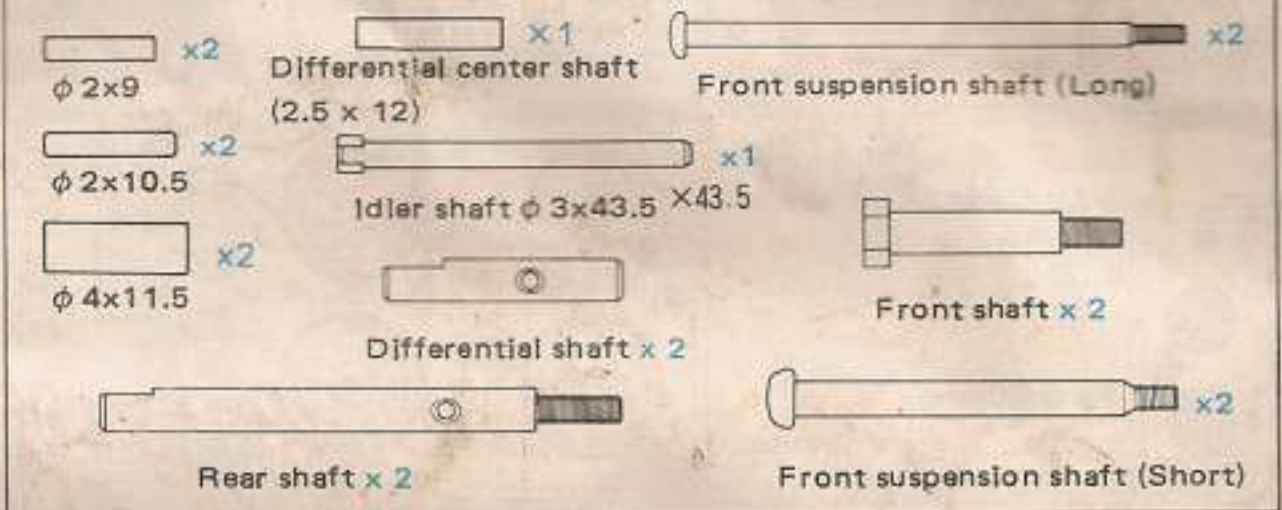

## A set



## B set

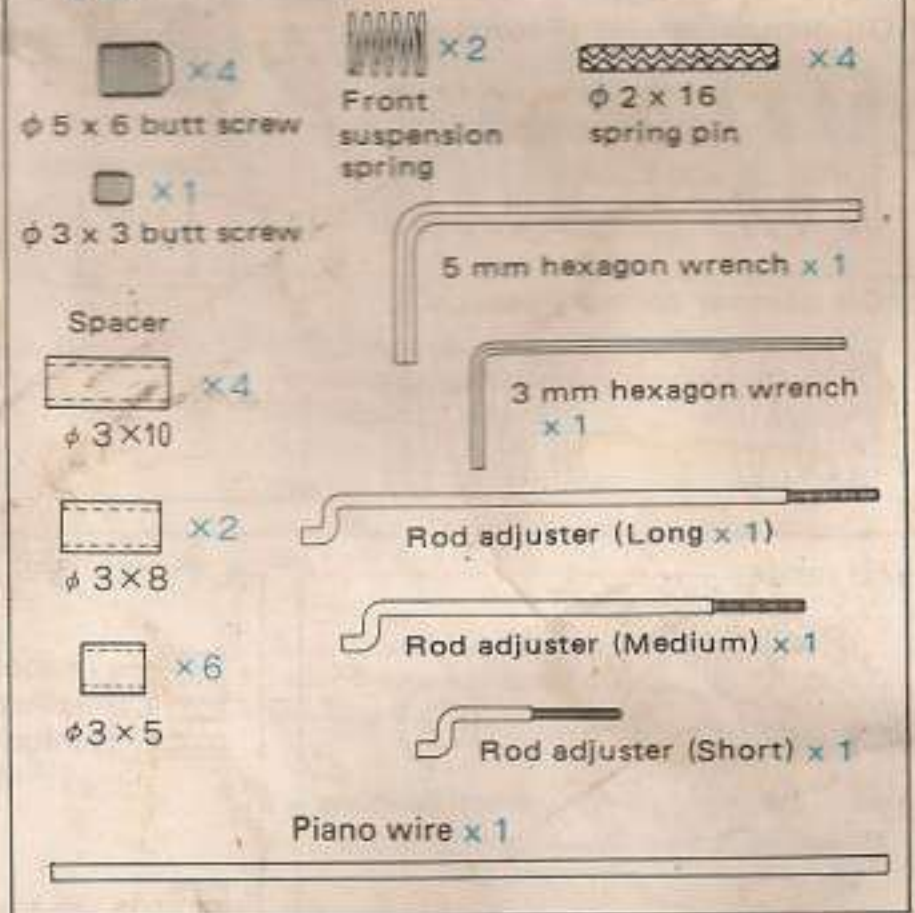

## Connector set

